

**MUNICIPALITY OF VAL RITA-HARTY
COMMUNITY CENTRE BOILER SYSTEM UPGRADES
PROJECT NO. 6637
DECEMBER 2023**

Piotrowski Consultants Ltd.
1820 Bond Street
North Bay, ON P1B 4V6

INDEX

SECTION	DESCRIPTION	PAGES
00100	Instructions to Bidders	6
00101	Agreement Between Contractor and Owner Tender Form	1 2
00131	Asbestos Survey	1
00800	Supplementary General Conditions	25
01005	General Instructions	3
01300	Submittals	3
01400	Quality Control	2
01545	Safety Requirements	1
01600	Material and Equipment	3
01700	Contract Closeout	3
15010	Mechanical General Requirements	11
15130	Thermometers and Pressure Gauges	3
15140	Pipe Hangers and Supports	4
15190	Identification	6
15260	Thermal Insulation for Piping	5
15280	Thermal Insulation for Equipment	4
15412	Domestic Water Supply – Copper	3
15413	Drainage Waste and Vent Piping: Cast Iron and Copper	2
15482	Pipes, Valves and Fittings - Gas	4
15513	Hydronic Systems – Steel Piping, Valves and Fittings	7
15515	Hydronic Specialties	5
15540	Hydronic Systems – Pumps	5
15545	HVAC Water Treatment Systems	3
15555	Low Pressure Packaged Boilers	5
15990	Testing, Adjusting and Balancing (TAB)	5
16010	Electrical General Requirements	7
16111	Conduits, Conduit Fastenings and Conduit Fittings	3
16122	Wires and Cables - 0 - 1000 V	3
16132	Outlet Boxes, Conduit Boxes and Fittings	2
16151	Wire and Box Connections - 0-1000 V	2
16191	Fastenings and Supports	2
16440	Disconnect Switches – Fused and Non-Fused up to 1000V	2
16450	Grounding - Secondary	2
16477	Moulded Case Circuit Breakers	1

PART 1 - GENERAL

1.1 LOCATION

- .1 Municipality of Val Rita-Harty Community Centre is located at 106 Government Road, Val Rita-Harty, ON.

1.2 RESERVED RIGHTS

- .1 The Owner reserves the right to reject any or all tenders in their best interest. The lowest or any tender shall not necessarily be accepted.
- .2 Tenders which are incomplete, conditional, illegible, or obscure, or that contain additions not called for, reservations, erasures, alterations or irregularities of any kind may be rejected as informal.
- .3 Tenders that contain prices which appear to be so unbalanced as likely to affect adversely the interests of the Owner may be rejected.
- .4 Wherever in a tender the amount tendered for an item does not agree with the extension of the estimated quantity and the tendered unit price, the unit price shall govern and the amount of the Total Tender Price shall be corrected accordingly.
- .5 The award of any contract shall be conditional upon funding availability as dictated by the budget of the Municipality of Val Rita-Harty.
- .6 This tender shall remain open for acceptance for a period of 60 days.

1.3 DELIVERY AND OPENING OF TENDERS

- .1 Tenders sealed in the envelope provided; marked "Municipality of Val Rita-Harty Community Centre Boiler System Upgrades, 106 Government Road, P.O. Box 100, Val Rita- Harty, ON P0H 2G0." will be received by January 23, 2024 until 2:00 p.m. and no later than 2:00 p.m. local time date.
- .2 Under no circumstances will tenders be considered which: a) are received after 2:00 p.m., the advertised closing date for tenders, i.e. 2:01 p.m.; b) are not accompanied by a tender deposit as specified; c) are not received in the official tender envelope.

1.4 WITHDRAWAL OR QUALIFYING OF TENDERS

- .1 A tenderer who has already submitted a tender may submit a further tender at any time up to the Official closing time. The last tender received shall supersede and invalidate a tender previously submitted by that tenderer for this Contract.
- .2 A tenderer may withdraw or qualify his tender at any time up to the Official closing time by submitting a letter bearing his signature and seal as in his tender to the Owner who will mark there on the time and date of receipt and will place the letter in the tender box. No facsimile,

telegraph or telephone calls will be considered.

1.5 COMPLETION DATE

- .1 The construction time is from date of award to August 30, 2024.

1.6 TENDER DEPOSIT

- .1 Every tender must be accompanied by a deposit in the form of a Bid Bond in the amount of 15% of the value of the tender. (A certified cheque, 15% of the value of the contract will be accepted in lieu of a bid bond.)
- .2 The amount of Tender Deposit shall be stated in the appropriate part of the Form of Tender. If a tenderer, after he has been notified that his tender has been recommended to the Owner for acceptance, fails to execute the agreement and provide the Contract Bond and other documents as herein specified, the Owner may retain the tender deposit for his use and may accept any other tender, or call new tenders.
- .3 The tender deposits of all tenderers except the two lowest tenderers will be returned immediately following the award of the Contract. The tender deposits of the two low tenderers will be retained until the other documents required herein have been furnished to the satisfaction of the Owner and the Engineer., save that if a tenderer has not been notified that his tender has been recommended to the Owner for acceptance, within 60 days after the date of opening tenders, their tender deposit will be returned on demand and if a tender has not been accepted and the Agreement executed within 90 days after the date of opening tenders, any remaining tender deposit will be returned.

1.7 INFLUENCE

- .1 No person, company, corporation or organization shall attempt in any way, either in private or in public, to influence the outcome of any The Municipality of Val Rita-Harty purchasing or disposal process. The bid, quotation or proposal of any person, company, corporation or organization that does attempt to influence the outcome of any Municipality of Val Rita-Harty purchasing or disposal process will be disqualified, and the person, company, corporation or organization may be subjected to exclusion or suspension under the Vendor Performance Policy.

1.8 HEALTH & SAFETY

- .1 The contractor shall perform all work in compliance with the Occupational Health and Safety Act of Ontario.
- .2 The Contractor acknowledges its duty as an employer and a supervisor under the Occupational Health and Safety Act and under the applicable regulations and in particular, that the Contractor shall take every precaution reasonable under the circumstances for the protection of a worker.
- .3 The Contractor acknowledges possession of a copy of the Occupational Health and Safety Act and applicable regulations for this contract.

- .4 The Contractor shall provide all required safety and personal protective equipment as required under the Occupational Health and Safety Act or the Safety Policies of the Contractor. The Municipality of Val Rita-Harty has the right to stop the work if improper performance of any kind is being carried out.
- .5 The Contractor releases and discharges the Municipality of Val Rita-Harty and Piotrowski Consultants Ltd. from any claim or demand for any action taken by the Municipality of Val Rita-Harty to exercise its duties of due diligence under the Occupational Health and Safety Act.

1.9 INDEMNITY

- .1 The Contractor agrees to indemnify and save harmless Municipality of Val Rita-Harty and Piotrowski Consultants Ltd. from any claim or demand arising as a result of the performance or non-performance of this Contract by the Contractor, and without limiting the generality of the foregoing, the Contractor agrees to indemnify and save harmless Municipality of Val Rita-Harty and Piotrowski Consultants Ltd. from any claim or demand arising after the expiry of any reasonable time limit fixed by Municipality of Val Rita-Harty for the completion of any work as assigned from time to time.

1.10 ENVIRONMENTAL CONTROL

- .1 The contractor is responsible for the site environmental and shall be responsible for any and all damages, spills, site clean-up and restoration, according to applicable codes, standards, practices, and legislation for any issues caused as a result of the contractor's work and equipment on site.

1.11 APPLICABLE LEGISLATION

- .1 All work shall meet any and all applicable codes, legislation (Acts and Regulations), practices, and standards in relation to the works.
- .2 The Contractor shall be responsible for all cable locates and required permits required for commencement and completion of the work specified.

1.12 SEPARATE AND ALTERNATE PRICES

- .1 All bidders shall submit all separate and/or alternate prices on the Tender Form in the spaces provided, or as called for in the specifications or on the drawings. All bidders shall examine Tender Form of these specifications carefully.

1.13 ABILITY AND EXPERIENCE OF TENDERER

- .1 It is not the intention of Municipality of Val Rita-Harty to award this Contract to any Tenderer who does not furnish satisfactory evidence that he has sufficient capital and plant to enable him to execute and complete the same successfully, and to complete it within the time stated in the Contract.

1.14 BIDDER'S CONFERENCE

- .1 A mandatory bidder's conference will take place on January 16, 2024 at 10:00am. Failure to attend will render your bid non-responsive.

1.15 DISCREPANCIES AND/OR OMISSIONS

- .1 Should a tenderer find discrepancies in, or omissions from the drawings, specifications or other tender documents, or should he be in doubt as to their meaning, he should notify the Purchasing Manager, preferably in writing and not later than eight days before the closing date for tenders. If the Purchasing Manager considers that a correction, explanation or interpretation is necessary or desirable, he will issue an addendum to all who have taken out tender documents.

1.16 INTERPRETATIONS AND ADDENDA

- .1 No oral interpretations shall be made to a tenderer as to the meaning of any of the tender documents, or be effective to modify any other provisions of the tender documents. Every request for an interpretation shall be made in writing, addressed and forwarded to the Site Authority.
- .2 Tenderers, may be advised during the tendering period, by Addenda, of required additions to, deletions from or alterations in the requirements of the tender documents. All such changes shall become an integral part of the tender documents, and shall be allowed for in arriving at the fixed tender sum.
- .3 Tenderers shall insert, in the space provided on the Tender form, the addenda numbers of all Addenda received by them during the tendering period, including any bound into the contract documents. If no Addenda have been received, the work, "NONE" shall be inserted in the space provided on the Tender Form.

1.17 INQUIRIES

- .1 All inquiries regarding tender documents should be directed to the following contact persons:

Thomas Krajci, M.E.Sc., P. Eng.
Piotrowski Consultants Ltd.
Telephone (705) 472-2536 Fax (705) 476-5105
Email: pcl@piotrowskiconsultants.ca

1.18 EQUALS

- .1 It is intended that all materials specified in the specifications shall be used with no equals. Should a contractor desire to use "equals" must be approved by the Consultant in writing, seven (7) full working days prior to the closing date of tenders. No "equals" shall be allowed after closing date of tenders.

1.1. BONDING

- .1 Performance Bond and Labour and Material Payment Bond to be provided – 50% (Specification Section 00800 – 43 Contract Security). (A certified cheque, 50% of the value of the contract will be accepted in lieu of a bid bond)

1.19 WARRANTY

- .1 Full warranty shall be provided for a period of one (1) year.
- .2 It shall be specifically understood that the one year (1 year) period of warranty from the date of Substantial Performance, refers to the date of Substantial Performance of the entire contract and does not refer to dates of Substantial or Total Performance by subcontractors and/or Delivery of Products by Suppliers.
- .3 The entire project, all work and products, shall be under warranty or as specified for a period of one (1) year from the date of Substantial Performance of the entire contract. This condition also applies to subcontractors and suppliers who may have completed their work prior to the substantial performance date referred to above.
- .4 In the case of warranty work required, that portion of the work or products under repair, shall be warranted for a further period of one year (1 year) from the date of repair work or replacement performed.
- .5 Provide longer than one year (1 year) warranties or guarantees where required by the Contract Documents.

1.21 INSURANCE

- .1 The Contractor agrees to Indemnify and save harmless the Municipality of Val Rita-Harty and Piotrowski Consultants Ltd. for any claim demand arising out of the performance by the Contractor of the Contract. The Contractor agrees to maintain comprehensive liability insurance covering all operations and liability assumed under the Contract. Have a limit of liability of not less than \$2,000,000.00 inclusive for any one occurrence

1.22 WORKPLACE SAFETY AND INSURANCE BOARD

- .1 The tenderer whose tender has been recommended to the Owner for acceptance shall submit such Statutory Declaration, or a satisfactory clearance letter from the Work Place Safety and Insurance Board, to the Owner. One (1) copy of the Statutory Declaration or clearance letter shall be bound into each of the four (4) executed sets of the Contract.

1.23 SALES TAX

- .1 All sales taxes shall be included. The Contractors will be requested to submit the copies of material invoices to Owners.

1.24 LIST OF CONTRACT DOCUMENTS

- .1 The contract documents Canadian Standard Construction Documents C.C.D.C #2 2008 Stipulated Price Contract.
- .2 Specifications for Municipality of Val Rita-Harty Community Centre Boiler System Upgrades.
- .3 Drawings:

Mechanical – M101 – M102
Electrical – E101

END OF SECTION 00100

1.1. GENERAL

1. The successful tenders, when awarded the Contract, shall be required to sign the Canadian Standard Construction Document C.C.D.C. #2 2008 Edition of the Stipulated Price Contract and the General Conditions of the Stipulated Price Contract, G.C. #1 to G.C. #12 inclusive and CCDC 41 as amended by the contract.
2. The foregoing document shall be considered as though bound herein and as an integral part of these specifications.
3. Where the term "Contract" is referred to in these specifications, it shall be understood to be this agreement for as described herein.
4. Where the term "Contract Documents" is referred to in these specifications, it shall be understood to be all of the documents including all drawings in the list of contract documents.
5. Failure of any bidder to inspect the contract documents shall signify he has read and acquainted himself fully with the terms of the documents from his own sources.
6. It is solely the responsibility of the tenderers to inspect and acquaint themselves with the conditions of the contract documents.

**MUNICIPALITY OF VAL RITA-HARTY
COMMUNITY CENTRE BOILER SYSTEM UPGRADES
PROJECT NO. 6637
TENDER FORM**

Date: _____

We: _____

(Name of Contractual Firm)

Hereby submit our proposal for work described by the Following Contract Documents:

Community Centre Boiler System Upgrades
Municipality of Val Rita-Harty
Project No. 6637
Dated: December 2023

We have examined these documents, and also Addendum(s) numbered __ and dated _____ (if applicable) and are familiar with all conditions affecting work.

The Undersigned proposes to furnish Labour, Materials, Equipment and Appliances required by the said documents for the project, for the Stipulated Sum of (excluding HST):

Base Bid Tender Price:

_____ (written in words)

_____ (\$ _____)
(written in numerals)

HST in the amount of _____ (written in words)

_____ (\$ _____)
(written in numerals)

Subcontractors

The following sub-contractors will be engaged by the undersigned to complete the work described in the Contract Documents. See Section 00100 Instructions to Bidders, Item 1.9 Subcontractor Identification for details regarding this list, its use and implications.

General _____ Tel: _____

Mechanical _____ Tel: _____

Electrical _____ Tel: _____

**COMMUNITY CENTRE BOILER SYSTEM UPGRADES
MUNICIPALITY OF VAL RITA-HARTY
PROJECT NO: 6637
TENDOR FORM
PAGE 2**

Complete Tender Form, signed under seal, executed and dated submitted in sealed envelope, clearly marked **MUNICIPALITY OF VAL RITA-HARTY COMMUNITY CENTRE BOILER SYSTEM UPGRADES**, will be received until **January 23rd, 2024 at 2:00:00 p.m. local time.**

Tender Forms submitted after 2:00:00 p.m. on the date noted above, will be returned to the Bidder unopened.

This Tender shall be valid for 60 days from the Tender Closing Date.

The Board reserves the right to reject any or all Tenders or to accept any that are beneficial to the Board.

We are in a position to commence work immediately upon receipt of a Purchase Order, and guarantee to meet deadlines indicated herein.

Construction Schedule for Project is May 1, 2024 to August 30, 2024.

The Undersigned to provide a Certificate of Good Standing from the WSIB , Proof of Insurance, Bid Bond and Agreement to Bond to be submitted with Tender Bid Form.

COMPANY NAME _____

SIGNATURE OF AUTHORIZED PRINCIPAL _____

TYPED NAME OF AUTHORIZED PRINCIPAL _____

DATE _____

ADDRESS _____

TELEPHONE _____

SEAL _____
(Witness – in case of no seal)

PART 1- GENERAL

1.1. DESIGNATED SUBSTANCE SURVEY

1. The following is the Owner's designated substance survey report.
2. This Survey Report was prepared by its author for the Owner and is hereby offered to the bidder in good faith for general information and guidance. The Consultant assumes no responsibility or liability for the completeness and accuracy of the information contained in this report.
3. The Designated Substance Survey is provided for the Contractor's information. The Contractor shall review the report and advise the Consultant in advance of any areas where they expect existing asbestos containing building materials to be disturbed as part of the Work, where abatement is not currently specified to be included in the Work.
4. Should there be a discrepancy between recommendations contained in the report and the requirements of the Contract Documents, the latter shall govern. Advise the Consultant in writing prior to proceeding with the Work.

1. GENERAL

- 1.1 The General Conditions of the Canadian Construction Document Committee – CCDC 2-2008 – Stipulated Price Contract, Articles GC-1 through GC-12 inclusive shall form part of this Contract.
- 1.2 The following Supplementary Conditions modify, change, delete from and/or add to the Articles of Agreement, the Definitions, and the General Conditions of the Stipulated Price Contract CCDC 2 – 2008.
- 1.3 When any Article, Definition, General Condition, Paragraph, or Sub-paragraph in the Agreement and/or General Conditions is supplemented by one of the following paragraphs, the provision of such Article, Paragraph or Sub-Paragraph shall remain in effect and the supplemental provisions shall be considered as added thereto.
- 1.4 Where any Article, Definition, General Condition, Paragraph or Sub-Paragraph in the Agreement and/or General Conditions is amended, voided or superseded by any of the following paragraphs, the provision of such Article, Definition, General Condition, Paragraph or Sub-Paragraph not so amended, voided, or superseded shall remain in effect.
- 1.5 The term “provide” as used in the Contract Documents, shall mean the furnishing of all labour, materials, equipment, transportation and all other services required, including all costs in connection therewith, to complete the Work.
- 1.6 Where the word “submit”, “satisfactory”, “approved”, “designated”, “directed”, “inspected”, “instructed”, “permitted”, “required”, “ordered” or other similar term is used throughout the Contract Documents, it shall be followed by the words, “by the Consultant” unless the contract provides otherwise.
- 1.7 Where the words “by other” are used in the Specifications or on the drawings, they will not mean by someone other than the Contractor. The only means by which something shown or specified will be indicated as not being in the Contract is by the use of initials “NIC” or the words “Not In Contract” or “By Owner”.
- 1.8 Throughout the Contract Documents, wherein the term “Day” is used, amend to read: “Working Day”, as defined in Definitions.
- 1.9 The following Articles, Definitions, General Conditions, Paragraphs, Sub-paragraphs or clauses thereof have been modified in these Supplementary Conditions.

2. MODIFICATIONS TO AGREEMENT BETWEEN OWNER AND CONTRACTOR

2.1 ARTICLE A-5 – PAYMENT

- 2.1.1 Insert the following values in the blanks of Paragraphs 5.1 “ten” and “10”.
- 2.1.2 Insert the following in the blanks of Paragraph 5.3.1 “The Bank of Canada”.
- 2.1.3 Add the following new Paragraph.
 - “5.4 The Consultant may withhold or nullify, in whole or in part, any application for payment to such extent as may be necessary to protect the Owner from loss because of the following:
 - .1 defective work not remedied,
 - .2 claims filed or reasonable evidence indicating probable filing of claims,
 - .3 failure of Contractor to make payment properly to Subcontractors or suppliers for material and/or labour,
 - .4 damage to the work of another Contractor,
 - .5 unauthorized deviations by Contractor from Contract Documents,
 - .6 unsatisfactory progress of project work by Contractor,

.7 record drawings not current and up-to-date with changes.

When the above noted grounds are resolved, payments will be made for amounts withheld. No interest will be paid on amounts withheld.

2.2 ARTICLE A-6 – RECEIPT OF AND ADDRESSES FOR NOTICES IN WRITING

2.2.1 Amend Paragraph 6.1 to read:

"6.1 Notices in Writing between the parties, or between them and the Consultant, shall be considered to have been received by the addressee on the date of receipt if delivered by hand or by commercial courier or if sent during normal business hours by fax and addressed as set out below. Such Notices in Writing will be deemed to be received by the addressee on next business day if sent by fax after normal business hours or if sent by overnight commercial courier. Such Notices in Writing will be deemed by be received by the addressee on the fifth Working Day following the date of mailing if sent by pre-paid registered post, where addressed as set out below. An address for a party may be changed y Notice in Writing to the other party setting out the new address in accordance with this article."

3. DEFINITIONS

3.1 Amend Definition 4 by adding the following to the end of that Definition:

"For purposes of the *Contract*, the terms "Consultant", "Architect" and "Engineer" shall be considered synonymous."

3.2 Amend Definition 12 by adding the following to the end of that Definition:

"For purposes of the *Contract*, the terms "Owner", "Near North District School Board" shall be considered synonymous.

3.3 Amend Definition 16, Provide, as follows:

"*Provide*' means to supply and install. *Provide* has this meaning whether or not the first letter is capitalized."

3.4 Add a new Definition 27, Act, as follows:

" *Act*' means the Construction Lien Act (Ontario)."

3.5 Add a new Definition 28, Construction Schedule, as follows:

"*Construction Schedule*' means the schedule for the performance of the *Work* provided by the *Contractor* pursuant to GC3.5, including any amendments to the *Construction Schedule* made pursuant to the *Contract Documents*."

3.6 Add a new Definition 29, Environmental Programs, as follows:

"*Environmental Programs*" means the environmental plans, programs, procedures and requirements of the *Owner* found in the manual prepared and maintained by the *Owner* and referred to in the Instructions to Bidders. The *Environmental Programs* include *Owner's* Asbestos Control Program, its mould program and a program for controlling and handling designated substances."

3.7 Add a new Definition 30, Exposed, as follows:

"*Exposed*" means visible by the *Owner* at the completion of the *Work*, unless otherwise indicated in the *Contract Documents*. *Exposed* items include all items on roof areas, mechanical and service rooms, inside of cupboards, cabinets and similar items."

- 3.8 Add a new Definition 31, Force Majeure, as follows:

"*Force Majeure*" means any cause, beyond the *Contractor's* control, other than bankruptcy or insolvency, which prevents the performance by the *Contractor* of any of its obligations under the *Contract* and the event of *Force Majeure* was not caused by the *Contractor's* default or active commission or omission and could not be avoided or mitigated by the exercise of reasonable effort or foresight by the *Contractor*. *Force Majeure* includes *Labour Disputes*, fire, unusual delay by common carriers or unavoidable casualties, civil disturbance, acts, orders, legislation, regulations or directives of any government or other public authority, acts of a public enemy, war, riot, sabotage, blockage embargo, shortage of materials and supplies, lightning, earthquake, abnormally adverse weather conditions or acts of God."

- 3.9 Add a new Definition 32, Install, as follows:

"*Install*" means install and connect. *Install* has this meaning whether or not the first letter is capitalized."

- 3.10 Add a new Definition 33, Labour Dispute, as follows:

"*Labour Dispute*" means any lawful or unlawful labour problems, work stoppage, labour disruption, strike (including lockouts decreed or recommended for its members by a recognized contractor's association of which the *Contractor* is a member or to which the *Contractor* is otherwise bound), job action, slow down, picketing, refusal to work or continue to work, refusal to supply materials, cessation or work or other labour controversy which does, or might, affect the *Work*."

- 3.11 Add a new Definition 34, OHSA, as follows:

"*OHSA*" means the Occupational Health and Safety Act (Ontario)"

- 3.12 Add a new Definition 35, Request for Information, as follows:

"*Request for Information*" or '*RFI*' means written documentation sent by the *Contractor* to the *Owner* or to the *Owner's* representative or to the *Consultant* requesting written clarification(s) and/or interpretation(s) of the *Drawings* and/or *Specifications*, *Contract* requirements and/or other pertinent information required to complete the *Work* of the *Contract* without applying for a change or changes to the *Work*."

- 3.13 Add a new Definition 36, Submittals, as follows:

"*Submittals*" means documents or items required by the *Contract Documents* to be provided by the *Contractor* such as:

- *Shop Drawings*, samples, models, mock-ups to indicate details or characteristics, before the portion of the *Work* that they represent can be incorporated into the *Work*; and,
- Record drawings and manuals to provide instructions to the operation and maintenance of the *Work*"

- 3.14 Add a new Definition 37, reviewed, instructed, required, directed, permitted, inspected, ordered, as follows:

"Wherever the words 'reviewed', 'instructed', 'required', 'directed', 'permitted', 'inspected', 'ordered' or

similar words are used they shall mean, unless the context provides otherwise, 'reviewed by the *Consultant*', 'instructed by the *Consultant*', 'required by the *Consultant*', 'directed by the *Consultant*', 'permitted by the *Consultant*' and 'ordered by the *Consultant*.'

- 3.15 Add a new Definition 38, satisfactory, as follows:

"Wherever the word 'satisfactory' or similar words or phrases are used in the Contract Documents, it means, unless the context provides otherwise, 'satisfactory to the Owner and the Consultant'."

- 3.16 Add a new Definition 39, As-Constructed Documents, as follows:

"As-constructed documents refer to reproductions of the original drawings and specifications which have been marked up to accurately show all changes from the original documents and which are to be provided in clearly marked and legible hard copies. As-constructed documents may also be known as As-Built Drawings."

- 3.17 Add a new Definition 40, Constructor, as follows:

"The Constructor is as defined in the Occupational Health and Safety Act, R.S.O. 1990 (latest amendment), referring to the person undertaking the project for the Owner, and for the purposes of this project, shall be the Contractor."

- 3.18 Add a new Definition 41, Proper Invoice, as follows:

"For purposes of the Contract, the terms "Proper Invoice", "Progress Application", and "Contractor Application for Payment" shall be considered synonymous."

- 3.19 Add a new Definition 42, Collusion, as follows:

"Collusion: a non-competitive, secret, and sometimes illegal agreement between rivals which attempts to disrupt the market's equilibrium"

4. AMENDMENTS TO THE GENERAL CONDITIONS OF THE STIPULATED PRICE CONTRACT GC 1.1 CONTRACT DOCUMENTS

- 4.1 Amend paragraph 1.1.1 by adding the following between the first and second sentences:

"In many cases, the language of the *Contract Documents* is written in the imperative for the sake of brevity. Clauses containing instructions or directions are intended for the *Contractor* and such sentences are deemed to include the words, ... "the *Contractor* shall"."

- 4.2 Amend paragraph 1.1.6 by adding the following to the end of that paragraph:

"The *Specifications* are divided into divisions and sections for convenience but shall be read as a whole and neither such division nor anything else contained in the *Contract Documents* will be construed to place responsibility on the *Consultant* to settle disputes among the *Subcontractors* and *Suppliers* in respect to such divisions. The Drawings are, in part, diagrammatic and are intended to convey the scope of the *Work* and indicate general and appropriate locations, arrangement and sizes of fixtures, equipment and outlets. The *Contractor* shall obtain more accurate information about the locations, arrangement and sizes from study and coordination of the Drawings, including *Shop Drawings* and shall become familiar with conditions and spaces affecting these matters before proceeding with the *Work*. Where site conditions require reasonable minor changes in indicated locations and arrangements, the *Contractor* shall make such changes at no additional cost to the Owner. Similarly, where known conditions or existing conditions interfere with new installation and require relocation, the *Contractor* shall include such relocation in the *Work*. The *Contractor* shall arrange and install fixtures and equipment in such a way as to conserve as much headroom and space as possible. The schedules are that portion of the *Contract Documents* wherever located and whenever issued, compiling information of similar content and may consist of drawings, tables and/or lists."

- 4.3 Amend paragraph 1.1.7 by adding subparagraphs 1.1.7.5, 1.1.7.6, 1.1.7.7, 1.1.7.8, and 1.1.7.9 as follows:

.5 Annotations on the *Drawings* shall govern over the graphic representation of the *Drawings*.
.6 Finishes in the room finish schedules shall govern over those shown on the *Drawings*.
.7 Schedules of Division 01 – General Requirements of the *Specifications* shall form part of and be read in conjunction with the technical specification section as listed in the table of contents of the *Specifications*.

- 4.4 Delete paragraph 1.1.8 in its entirety and substitute new paragraph 1.1.8:

“1.1.8 The Contractor will be issued electronic copies of “Issued for Tender, Permit, and Construction”. The documents will be issued in PDF format. The production of hardcopies of the document will be at the expense of the Contractor as necessary to facilitate the construction of the building.”

- 4.5 Add a new paragraph 1.1.11 as follows:

“1.1.11 One set of signed and sealed *Contract Documents* shall be retained by each of the *Owner* and the *Contractor*.”

5. GC 2.2 ROLE OF THE CONSULTANT

- 5.1 Delete Paragraph 2.2.4 in its entirety.

- 5.2 Revise Paragraph 2.2.6 to read:

The *Consultant* will not be responsible for and will not have control, charge or supervision of construction means, methods, schedules, techniques, sequences or procedures, or for safety precautions and programs required in connection with the *Work* in accordance with the applicable construction safety legislation, other regulations or general construction practice. The *Consultant* will not be responsible for the *Contractor's* failure to carry out the *Work* in accordance with the *Contract Documents* or adhere to the construction schedule. The *Consultant* will not have control over, charge of or be responsible for the acts or omissions of the *Contractor*, *Subcontractors*, *Suppliers*, or their agents, employees, or any other persons performing portions of the *Work*.

- 5.3 Amend paragraph 2.2.7 in the second and third lines by deleting the words: “...except with respect to GC5.1 —FINANCING INFORMATION REQUIRED OF THE OWNER”.

- 5.4 Reference paragraph 2.2.9, add the words:

“The Contractor shall waive any claims against the Consultant arising out of the making of such interpretations and findings in accordance with Paragraphs 2.2.7, 2.2.8 and 2.2.9 at the end of the Paragraph.”

- 5.5 Add the following to the end of paragraph 2.2.11:

“The Consultant’s obligation to make findings on a large claim or large number of claims is subject to the terms and conditions of the Owner/Consultant Agreement.”

- 5.6 Amend paragraph 2.2.13 by adding the following to the end of that paragraph:

“If, in the opinion of the *Contractor*, the Supplemental Instruction involves an adjustment in the *Contract Price* or in the Contract Time, it shall, within ten (10) *Working* days of receipt of a Supplemental Instruction provide the *Consultant* with a written notice to that effect. In the event that the *Contractor* needs additional information to determine whether a Supplemental Instruction involves an adjustment of the *Contract Price* or in the Contract Time, it may issue a written request

to the *Consultant* seeking such additional information. Following receipt of such information, the *Contractor* shall, within ten (10) *Working* days of receipt of such additional information provide the *Consultant* with the written notice described in the first sentence of this paragraph 2.2.13. Failure to provide written notification within the time stipulated in this paragraph 2.2.13 shall be deemed an acceptance of the Supplemental Instruction by the *Contractor* without adjustment in the *Contract Price* or *Contract Time*."

- 5.7 Amend paragraph 2.2.14 to read:

"The *Consultant* will review and take appropriate action upon Shop Drawings, Samples and other *Contractor's* Submittals, which are provided, in accordance with *Contract Documents*.

- 5.8 Add new paragraphs 2.2.19 and 2.2.20 as follows:

"2.2.19 The *Consultant's* services will be performed solely for the benefit of the *Owner* and no *Contractor*, *Subcontractor*, *Supplier* or other third party shall have any claim against the *Consultant* as a result of the performance or non-performance of the *Consultant's* services. The *Contractor* shall include this provision in any contracts it makes with its *Subcontractors*, *Suppliers* and others and shall require such *Subcontractors*, *Suppliers* and others to include the same term in their contracts with sub-*Subcontractors*, sub-*Suppliers* and others.

2.2.20 The *Specifications* are divided into divisions and sections for convenience but shall be read as a whole and neither such division nor anything else contained in the *Contract Documents* will be construed to place responsibility on the *Consultant* to settle disputes among *Subcontractors* and *Suppliers* in respect to such divisions."

6. GC 2.4 DEFECTIVE WORK

- 6.1 Add new subparagraphs 2.4.1.1, 2.4.1.2 and 2.4.1.3 as follows:

"2.4.1.1 The *Contractor* shall rectify, in a manner acceptable to the *Owner* and the *Consultant*, all defective work and deficiencies throughout the *Work*, whether or not they are specifically identified by the *Consultant*.

2.4.1.2 The *Contractor* shall prioritize the correction of any defective *Work* which, in the sole discretion of the *Owner*, adversely affects the day to day operation of the *Owner*.

2.4.1.3 The correction of any defective *Work* that is to take place after the *Owner* has taken occupancy must be completed after school hours or on weekends, unless otherwise agreed to between the *Owner* and *Contractor*."

7. GC 3.1 CONTROL OF THE WORK

- 7.1 Add a new paragraph 3.1.3 as follows:

3.1.3 Prior to commencing individual procurement, fabrication and construction activities, the *Contractor* shall verify, at the *Place of the Work*, all relevant measurements and levels necessary for proper and complete fabrication, assembly and installation of the *Work* and shall further carefully compare such field measurements and conditions with the requirements of the *Contract Documents*. Where dimensions are not included or exact locations are not apparent, the *Contractor* shall immediately notify the *Consultant* in writing and obtain written instructions from the *Consultant* before proceeding with any part of the affected *Work*.

8. GC 3.2 CONSTRUCTION BY OWNER OR OTHER CONTRACTORS

- 8.1 Delete subparagraphs 3.2.2.1 and 3.2.2.2 in their entirety and substitute "intentionally left blank".

- 8.2 Delete paragraph 3.2.3.2 and replace it with the following:
“3.2.3.2 Co-ordinate and schedule the activities and work of other contractors and *Owner’s* own forces with the Work of the *Contractor* and connect as specified or shown in the *Contract Documents*.”
- 8.3 Add a new paragraph 3.2.3.4 as follows:
“3.2.3.4 Subject to GC9.4 CONSTRUCTION SAFETY, for the *Owner’s* own forces and for other contractors, assume overall responsibility for compliance with all aspects of the applicable Health and Safety legislation of the *Place of the Work*, including all the responsibilities of the “constructor” under OHSA.”

9. GC 3.4 DOCUMENT REVIEW

- 9.1 Delete the second sentence of paragraph 3.4.1 and replace it with the following two sentences:
“Such review by the *Contractor* shall meet the standard of care described in paragraph 3.15.1 of this Contract. Except for the obligation to make such review and report the result, the *Contractor* does not assume any responsibility to the *Owner* or to the *Consultant* for the accuracy of the *Contract Documents*.”
- 9.2 Amend paragraph 3.4.1 in the fourth line, at the beginning of the third sentence, by adding the words, “Provided it has exercised the degree of care and skill described in this paragraph 3.4.1, the *Contractor*...”.
- 9.3 Add new paragraphs 3.4.2 and 3.4.3 as follows:
“3.4.2 Errors, inconsistencies and/or omissions in the Drawings and/or *Specifications* which do not allow completion of the *Work* of the Contract shall be brought to the *Consultant’s* attention prior to the execution of the Contract by means of an *RFI*.
3.4.3. Notwithstanding the foregoing, errors, inconsistencies, discrepancies and/or omissions shall not include lack of reference on the Drawings or in the *Specifications* to labour and/or *Products* that are required or normally recognized within respective trade practices as being necessary for the complete execution of the *Work*. The *Contractor* shall not use subsequent *RFIs*, issued during execution of the *Work*, to establish a change and/or changes in the *Work* pursuant to Part 6 – CHANGES IN THE *WORK*.”

10. GC 3.5 CONSTRUCTION SCHEDULE

- 10.1 Further amend paragraph 3.5.1 by adding a new subparagraph 3.5.1.2 as follows:
“3.5.1.2 provide the expertise and resources, such resources including manpower and equipment, as are necessary to maintain progress under the construction schedule referred to in paragraph 3.5.1.1 or any successor or revised schedule approved by the *Owner* pursuant to this GC3.5.”
- 10.2 Delete existing paragraph 3.5.1.2 and replace it with a new paragraph which is numbered 3.5.1.3 and reads as follows:
“3.5.1.3 continuously monitor the progress of the *Work* and provide a monthly progress schedule covering all of the baseline activities and including the actual start, actual finish and percentage completion of those activities. Each month, the *Contractor* shall submit, for the *Owner’s* approval, any changes made to the baseline logic and activity durations.”
- 10.3 Delete existing paragraph 3.5.1.3 and replace it with a new paragraph which is numbered 3.5.1.4 and reads as follows:

“3.5.1.4 if after applying the expertise and resources required under paragraph 3.5.1.2, the *Contractor* forms the opinion that the slippage in schedule reported in paragraph 3.5.1.3 cannot be recovered by the *Contractor*, it shall, in the same notice provided under paragraph 3.5.1.3, indicate to the *Consultant* if the *Contractor* intends to apply for an extension of Contract Time as provided in PART 6 —CHANGES IN THE WORK.”

10.4 Add a new paragraph 3.5.2 as follows:

“3.5.2 Without limiting the other obligations of the *Contractor* under GC3.5, the *Contractor* shall not amend the baseline schedule described in paragraph 3.5.1.1 without the prior written consent of the Owner. In addition, at each site construction meeting, the *Contractor* shall provide to the Owner and the *Consultant* a two (2) week look-ahead schedule indicating the major activities to be undertaken or constructed in such two (2) week period.”

11. GC 3.6 SUPERVISION

11.1 Delete paragraph 3.6.2 in its entirety and replace it with the following:

“3.6.2 The supervisor, and any project manager appointed by the *Contractor*, shall represent the *Contractor* at the Place of Work and shall have full authority to act on written instructions given by the *Consultant* and/or the Owner and the Owner’s representative. Instructions given to the supervisor or the project manager shall be deemed to have been given to the *Contractor* and both the supervisor and any project manager shall have full authority to act on behalf of the *Contractor* and bind the *Contractor* in matters related to this Contract.”

11.2 Add a new paragraph 3.6.3 as follows:

“3.6.3 The Owner, acting reasonably, shall have the right to order the *Contractor* to remove from the *Project* any representative or employee of the *Contractor*, *Subcontractors* or *Suppliers* who, in the opinion of the Owner, are a detriment to the *Project*.”

12. GC 3.7 SUBCONTRACTORS AND SUPPLIERS

12.1 Add a new paragraph 3.7.7 as follows:

“3.7.7 Where provided in the Contract, the Owner may assign to the *Contractor*, and the *Contractor* agrees to accept, any contract procured by the Owner for Work or services required on the *Project* that has been pre-tendered or pre-negotiated by the Owner.”

13. GC 3.8 LABOUR AND PRODUCTS

13.1 Amend paragraph 3.8.1 by adding the following sentence at the end of that paragraph:
“The *Contractor* represents and warrants that the *Products* provided for in accordance with the Contract are not subject to any conditional sales contract and are not subject to any security rights obtained by any third party which may subject any of the *Products* to seizure and/or removal from the *Place of the Work*.”

13.2 Delete paragraph 3.8.2 and replace it with the following:

“3.8.2 *Products* provided shall be new and shall conform to all current applicable specifications of the Canadian Standards Association, Canadian Standards Board or General Standards Board, ASTM, National Building Code, Ontario Building Code, National Fire Prevention Association, the Technical Standards and Safety Authority (also known as TSSA) and all governmental authorities having jurisdiction at the *Place of the Work*, unless otherwise specified. *Products* which are not specified shall be of a quality consistent with those specified and their use acceptable to the *Consultant*. *Products* brought on to the *Place of the Work* by the *Contractor*

shall be deemed to be the property of the Owner, but the *Owner* shall be under no liability for loss thereof or damage thereto arising from any cause whatsoever. The said Product shall be at the sole risk of the *Contractor*.”

13.3 Amend paragraph 3.8.3 by adding the words, “..., agents, Subcontractors and Suppliers. . .” after the “employees” toward the end of line one.

13.4 Also with respect to paragraph 3.8.3, add three new sentences to the end of this paragraph which read as follows:

“Without in any way limiting the generality of the foregoing, the *Contractor* shall prepare and implement the job site rules more particularly described in the tender documents. If no job site rules are described in the tender documents, the *Contractor* shall draft job site rules for the review and approval of the Owner. Any such job site rules prepared by the *Contractor* shall be consistent with the *Contractors* duties and obligations under the OHS/A and shall also include provisions making smoking and the consumption of alcohol or non-prescription drugs on the *Project* site the subject of discipline proceedings and/or termination of employment.”

13.5 Add new paragraphs 3.8.4, 3.8.5 and 3.8.6 as follows:

“3.8.4 Upon receipt of a written notice from the *Consultant*, the *Contractor* shall dismiss from the *Place of the Work* tradesmen and labourers whose *Work* is unsatisfactory to the *Consultant* or who are considered by the *Consultant* to be unskilled or otherwise objectionable.

3.8.5 The *Contractor* shall not employ any persons on the *Work* whose labour affiliation, or lack thereof, is incompatible with other labour employed in connection with the *Work*. Any costs arising from Labour Disputes, as a result of the employ of any such person by the *Contractor*, its Subcontractor or *Suppliers* shall be the sole expense of the *Contractor*.

3.8.6 The *Contractor* shall cooperate with the *Owner* and its representatives and shall take all reasonable and necessary actions to maintain stable and harmonious labour relations with respect to the *Work* at the *Place of the Work*, including cooperation to attempt to avoid *Work* stoppages, trade union jurisdictional disputes and other Labour Disputes.”

14. GC 3.9 DOCUMENTS AT THE SITE

14.1 Delete paragraph 3.9.1 in its entirety and replace it with the following:

3.9.1 The *Contractor* shall keep one copy of the current *Contract Documents*, *Supplemental Instructions*, *Contemplated Change Orders*, *Change Orders*, *Change Directives*, *Cash Allowance Disbursement Authorizations*, reviewed *Shop Drawings*, *Submittals*, reports and records of meetings at the *Place of the Work*, in good order and available to the *Owner* and *Consultant*.

15. GC 3.10 SHOP DRAWINGS

15.1 Add new paragraphs 3.10.13, 3.10.14, 3.10.15, 3.10.16, 3.10.17 and 3.10.18 as follows:

“3.10.13 Reviewed *Shop Drawings* shall not authorize a change in the *Contract Price* and/or the *Contract Time*.

3.10.14 The *Contractor* shall prepare a *Shop Drawings* schedule acceptable to the *Owner* and the *Consultant* prior to the first application for payment. A draft of the proposed *Shop Drawings* schedule shall be submitted by the *Contractor* to the *Consultant* and the *Owner* for approval. The draft *Shop Drawings* schedule shall clearly indicate the phasing of *Shop Drawings* submissions.

3.10.15 Except where the parties have agreed to a different *Shop Drawings* schedule pursuant to

paragraph 3.10.3, the *Contractor* shall comply with the requirements for *Shop Drawings* submissions stated in the *Specifications*, Section 01300, *Submittals*.

- 3.10.16 The *Contractor* shall not use the term “by others” on *Shop Drawings* or other *Submittals*. The related trade, Subcontractor or Supplier shall be stated.
- 3.10.17 Certain *Specifications* sections require the *Shop Drawings* to bear the seal and signature of a professional engineer. Such professional engineer must be registered in the jurisdiction of the *Place of the Work* and shall have expertise in the area of practice reflected in the *Shop Drawings*.
- 3.10.18 The *Consultant* will review and return *Shop Drawings* and *Submittals* in accordance with the Schedule agreed upon in 3.10.3, or, in the absence of such a schedule, with reasonable promptness. If, for any reason, the *Consultant* cannot process the *Shop Drawings* and/or *Submittals* within the agreed-upon schedule or with reasonable promptness, the *Consultant* shall notify the *Contractor* and they shall meet to review and arrive at an acceptable revised schedule for processing. The *Contractor* shall update the *Shop Drawings* and *Submittals* schedule to correspondence to changes in the construction schedule. Changes in the *Contract Price* or *Contract Time* may be made only as provided in the *Contract*.

16. GC 3.13 CLEANUP

16.1 Add new paragraph 3.13.4 as follows:

- 3.13.4 In the event that the *Contractor* fails to remove waste and debris as provided in this GC 3.13, then the *Owner* or the *Consultant*, may give the *Contractor* twenty-four (24) hours' written notice to meet its obligations respecting clean up. Should the *Contractor* fail to meet its obligations pursuant to this GC 3.13 within the twenty-four (24) hour period next following delivery of the notice, the *Owner* may remove such waste and debris and deduct from payments otherwise due to the *Contractor*, the *Owner's* costs for such clean up, including a reasonable markup for administration.”

17. GC 3.14 CONTRACTOR STANDARD OF CARE

17.1 Add a new General Condition 3.14 as follows:

“3.14 CONTRACTOR STANDARD OF CARE

- 3.14.1 In performing this *Contract*, the *Contractor* shall exercise the degree of care, skill and diligence that would normally be exercised by an experienced, skilled and prudent contractor supplying similar services for similar projects in a first class and expeditious manner. The *Contractor* acknowledges and agrees that, throughout this *Contract*, the *Contractor's* obligations, duties and responsibilities shall be judged, evaluated and interpreted in accordance with this standard. The *Contractor* shall exercise the same standard of care in respect of any *Products*, personnel or procedures which it may recommend to the *Owner* or employ on the *Project*.”

18. GC 3.15 CONTRACTOR USE OF PERMANENT EQUIPMENT OR SYSTEMS

18.1 Add a new General Condition 3.15 as follows:

“3.15 CONTRACTOR USE OF PERMANENT EQUIPMENT OR SYSTEMS

- 3.15.1 With the prior written approval of the *Owner*, the *Contractor* may make use of elements of the mechanical and electrical systems or equipment comprising a permanent part of the *Work* for the purpose of providing heat or power to the *Project* during the final stages of construction. In such event, and before the issuance of the certificate of Substantial Performance of the *Work*, the *Contractor* shall clean and make good, to the satisfaction of the *Consultant*, such systems

and equipment as it had been permitted to use. The *Contractor* shall pay any and all costs associated with such use, cleaning and making good."

19. GC 5.1 FINANCING INFORMATION REQUIRED OF THE OWNER

19.1 Delete GC5.1 in its entirety and replace it with "Intentionally left blank."

20. GC 5.2 APPLICATIONS FOR PROGRESS PAYMENT

20.1 Amend paragraph 5.2.3 by adding the following to the end of that paragraph:
"No amount claimed shall include *Products* delivered to the *Place of the Work* unless the *Products* are free and clear of all security interest, liens, and other claims of third parties."

20.2 Amend paragraph 5.2.4 by adding the following to the end of that paragraph:

"Such statement of values shall subdivide the *Contractor's* allocation for "general conditions" to identify a separate line item labeled "allocation for baseline schedule required by GC3.5." The allocation to such line item shall be calculated as follows:

.1 where the *Contract Price* is \$2,000,000 or less, the greater of \$5,000 and 5% of the total amount allocated by the *Contractor* to "general conditions;

In addition, the statement of values shall identify a separate line item labeled "allocation for warranty obligations described in GC12.3". The allocation to such line item shall be \$_0.30% of Stipulated Sum Price"

20.3 Amend paragraph 5.2.7 by adding the following new sentence at the end of that paragraph:

"Any *Products* delivered to the *Place of the Work* but not yet incorporated into the *Work* shall remain at the risk of the *Contractor* notwithstanding the title has passed to the *Owner* pursuant to GC13.1 OWNERSHIP OF MATERIALS."

20.4 Add new paragraphs 5.2.8, 5.2.9 and 5.2.10 as follows:

5.2.8 The *Contractor* shall submit, with each application for progress payment after the first, a Statutory Declaration, on an original form of CCDC Document 9A-2001, stating that all accounts for labour, subcontracts, *Products*, Construction Equipment and other indebtedness which may have been incurred by the *Contractor* and for which the *Owner* might in any way be held responsible have been paid in full up to the previous invoice, except for amounts properly retained as a holdback or as an identified amount in dispute

5.2.9 The *Contractor* shall submit Workplace Safety & Insurance Board Clearance Certificate, with each application for progress payment.

5.2.10 The *Contractor* shall prepare and maintain current as-built *Drawings* which shall consist of the *Drawings* and *Specifications* revised by the *Contractor* during the *Work*, showing changes to the *Drawings* and *Specifications*, which current as-built *Drawings* shall be maintained by the *Contractor* and made available to the *Consultant* for review with each application for progress payment. The *Consultant* reserves the right to retain a reasonable amount for the value of the as-built *Drawings* not presented for review.

5.2.11 Prior to each application for payment, the *Contractor*, *Consultant* and subconsultants shall jointly check the progress of the *Work* at the site.

5.2.12 Seven (7) calendar days prior to issuance of each proper invoice, the contractor shall issue a draft invoice for review by the *Consultant*."

21. GC 5.3 PROGRESS PAYMENTS

- 21.1 In paragraph 5.3.1, in the first line, revise the words “and application” to read, “a proper invoice”.
Add the following sentence at the end of the paragraph:
- “A proper invoice shall be submitted after acceptance of the draft invoice, as per Paragraph 5.2.12 above.”
- 21.2 Delete the present text of subparagraph 5.3.1.3 and substitute the following:
- “5.3.1.3 The Owner shall make payment to the Contractor as per the requirements of the Construction Act.”
- 21.3 In subparagraph 5.3.1.2, in the second line, revise the words “application for payment” to read, “formal application for payment.”
- 21.4 Add new paragraph 5.3.2, 5.3.4 and 5.3.5 as follows:
- “5.3.2 In the event a construction lien is registered against the *Place of the Work* in circumstances where the *Owner* is not in breach of its payment obligations under this *Contract*, then the *Contractor* shall, within seven (7) days of receiving notice of the construction lien, have the lien removed by way of discharge, settlement, or by posting security to vacate the registration of the lien. In the event that the *Contractor* fails to see to the removal of the construction lien, then without prejudice to any other right or remedy it may have, the *Owner* may see to the removal of the construction lien by payment into court or otherwise, and the costs of so doing shall be to the *Contractor’s* account.
- 5.3.4 All progress payments are not conclusive as to the value or quality of services provided and are subject to further evaluation and readjustment on future and final progress payments. The submission of monthly draw amounts by the *Contractor* and *Subcontractors* must reflect accurate valuations for *Work* completed and installed. The *Contractor* shall review and evaluate all *Subcontractors Work* and be responsible for verifying the monthly draw amounts claimed.
- 5.3.5 Once Substantial Performance of the *Work* has been achieved, no further applications for payment will be considered until the application for final payment. Final payment will be authorized by the *Consultant* only when all *Work* is entirely complete and all deficiencies are corrected.”

22. GC 5.4 SUBSTANTIAL PERFORMANCE OF THE WORK

- 22.1 Amend paragraph 5.4.3 by adding the following sentence at the end of the paragraph:
- “Immediately following the issuance of a certificate of Substantial Performance of the *Work*, the *Contractor* shall publish the Certificate in the manner provided in the *Act* failing which publication, the *Owner* shall be at liberty to publish and back charge the *Contractor* for its reasonable costs for doing so.”
- 22.2 Add a new paragraph 5.4.4 as follows:
- “5.4.4 The *Contractor* acknowledges that the *Submittals* described in this paragraph 5.4.4 are critical to the *Owner’s* use, occupancy and maintenance of the *Project* and agrees to make such *Submittals* to the *Owner*, before or after applying for the payment described in paragraph 5.4.1, as follows:
- .1 submit to the *Consultant*, with its application for payment, all written guarantees, warranties, certificates, testing and balancing reports, distribution system diagrams, *Shop Drawings*, maintenance and operating instructions, spare parts, maintenance manuals and materials and any other materials or documentation required by the *Contractor*, except for record drawings;

- .2 with respect to record or as built drawings, the *Contractor* shall submit full and complete record or as-built drawings to the *Consultant* within forty-five (45) days of the issuance of the certificate of Substantial Performance of the *Work* and the *Owner* shall be at liberty to withhold from amounts otherwise payable to the *Contractor* the sum of \$5,000.00 as security for the obligation of the *Contractor* to deliver such record or as built drawings within the time described in this paragraph 5.4.4.”

23. GC 5.5 PAYMENT OF HOLD BACK UPON SUBSTANTIAL PERFORMANCE OF THE WORK

- 23.1 Delete paragraph 5.5.3 in its entirety and substitute “Intentionally left blank”.

24. GC 5.6 PROGRESSIVE RELEASE OF HOLDBACK

- 24.1 Delete GC 5.6 in its entirety.

25. GC 5.7 FINAL PAYMENT

- 25.1 In paragraph 5.7.4, delete the words “no later than 5 calendar days after the issuance of a final certificate for payment”. In the same paragraph add the following words to the end of the paragraph, “...and as per the Construction Act”.

26. GC 6.1 CHANGES

- 26.1 Amend paragraph 6.1.2 by adding the following to the end of that paragraph:

“This requirement is of the essence and it is the express intention of the parties that any claims by the *Contractor* for a change in the *Contract Price* and/or *Contract Time* shall be barred unless there has been strict compliance with PART VI CHANGES IN THE *WORK*. No course of conduct or dealing between the parties, no express or implied acceptance of alterations or additions to the *Work* and no claims that the *Owner* has been unjustly enriched by any alteration or addition to the *Work*, whether in fact there is any such unjust enrichment or not, shall be the basis of a claim for additional payment under this Contract or a claim for any extension of the *Contract Time*.”

- 26.2 Add a new paragraph 6.1.3 as follows:

“The *Contractor* agrees that changes resulting from construction coordination including but not limited to site surface conditions, site coordination, Subcontractor and Supplier coordination are included in the *Contract Price* and shall not entitle the *Contractor* to claim in addition to the *Contract Price* in relation to coordination.”

27. GC 6.2 CHANGE ORDER

- 27.1 Add new paragraph 6.2.3 as follows:

“6.2.3 The value of a change shall be determined in one or more of the following methods as directed by the Owner:

- .1 by estimate and acceptance of a lump sum.
- .2 by unit prices established in the Contract or subsequently agreed upon. Unit Prices shall include overhead, profit, and other reasonable charges of the *Contractor* and shall be the total cost to the Owner. Adjustment to the *Contract Price* shall be based on a net quantity difference from the original quantity.”

- 27.2 Add new paragraph 6.2.4 as follows:

"6.2.4 For work done and products supplied by unit prices set out in the Contract or subsequently agreed upon, the Contractor shall calculate the new quantity of the work and/or product supplied and then only shall the tender unit price, or the previously agreed upon unit price be applied, the result either an extra or a credit to the contract sum."

27.3 Add new paragraph 6.2.5 as follows:

"6.2.5 For work done and products supplied by cost and a fixed or percentage fee, the contractor shall submit a completed itemized breakdown, substantiated with invoices for the products and time sheets for the work, showing the cost of the work and the products plus percentages as herein noted.

- .1 Subcontractor's mark up shall be five (5%) percent overhead and five (5%) percent profit, on which the Contract shall be allowed five (5) percent as administration and supervision fee.
- .2 Contractor's mark up, where no Subcontractor is involved shall be five (5%) percent overhead and five (5%) percent profit which shall include administration and supervision fee.
- .3 Cost of work shall be actual rates paid, plus the cost of actual statutory benefits."

28. GC 6.3 CHANGE DIRECTIVE

28.1 Delete paragraph 6.3.7.1 the introductory language and replace it with the following:

- .1 salaries, wages and benefits paid to personnel in the direct employ of the *Contractor*, applying the labour rates set out in the wage schedule in the *Contract Documents* or as otherwise agreed between the *Owner* and *Contractor* for personnel..."

28.2 Delete paragraphs 6.3.7.1(1), (2), (3) and (4) and replace them with the following:

- "(1) carrying out the *Work*, including necessary supervisory services;
- (2) intentionally left blank;
- (3) engaged in the preparation of *Shop Drawings*, fabrication drawings, coordination drawings and project record drawings: or...
- (4) including clerical staff engaged in processing changes in the *Work*."

28.3 Add new paragraph 6.3.14 as follows:

"6.3.14 Without limitation, the cost of performing the *Work* attributable to the Change Directive does not include:

- .1 head office salaries and benefits and all other overhead or general expenses, except only for the salaries, wages and benefits of personnel described in paragraph 6.3.4.2 and the contributions, assessments or taxes referred to in paragraphs 6.3.4.3;
- .2 capital expenses and interest on capital;
- .3 general clean-up, except where the performance of the *Work* in the Change Directive causes specific additional clean-up requirements;

- .4 wages paid for field supervision of *Subcontractors*;
- .5 wages, salaries, rentals, or other expenses that exceed the rates that are standard in the locality of the *Place of the Work* that are otherwise deemed unreasonable by the *Consultant*;
- .6 any costs or expenses attributable to the negligence, improper *Work*, deficiencies, or breaches of contract by the *Contractor* or *Subcontractor*; and
- .7 any cost of quality assurance, such as inspection and testing services, charges levied by authorities, and any legal fees unless any such costs or fees are pre-approved in writing by the *Owner*."

29. GC 6.4 CONCEALED OR UNKNOWN CONDITIONS

29.1 Delete paragraph 6.4.1 and replace it with the following:

"6.4.1.1 The *Contractor* confirms that, prior to tendering the *Project*, it carefully investigated the *Place of the Work* and applied to that investigation the degree of care and skill described in paragraph 3.15.1, given the amount of time provided between the issue of tender documents and the actual closing of tenders.

6.4.1.2 If the *Contractor* has not conducted such careful investigation, it is deemed to assume all risk of conditions or circumstances now existing or arising in the course of the *Work* which could make the *Work* more expensive or more difficult to perform than was contemplated at the time the *Contract* was executed. No claim by the *Contractor* will be entertained in connection with conditions which could reasonably have been ascertained by such investigation or other due diligence undertaken prior to the execution of the *Contract*."

29.2 Amend paragraph 6.4.2 by adding a new first sentence which reads as follows:

"6.4.2 Having regard to paragraph 6.4.1, if the *Contractor* believes that the conditions of the *Place of the Work* differ materially from those reasonably anticipated, differ materially from those indicated in the *Contract Documents* or were concealed from discovery notwithstanding the conduct of the investigation described in paragraph 6.4.1, it shall notify the *Owner* and *Consultant* in writing no later than five (5) *Working Days* after the first observation of such conditions."

29.3 Amend the existing second sentence of paragraph 6.4.2, in the second line, following the word "materially" by adding the words "or were concealed from discovery notwithstanding the conduct of the investigation described in paragraph 6.4.1."

29.4 Delete paragraph 6.4.3 and substitute the following:

"6.4.3 If the *Consultant* makes a finding pursuant to paragraph 6.4.2 that no change in the *Contract Price* or the *Contract Time* is justified, the *Consultant* shall report in writing the reasons for this finding to the *Owner* and the *Contractor*."

30. GC 6.5 DELAYS

30.1 Amend paragraphs 6.5.1 by deleting all of the words in the fifth line following the word "for" and substituting the following:

".....reasonable direct costs directly flowing from the delay but excluding any consequential, indirect or special damages."

30.2 Delete paragraph 6.5.3 and replace it with the following:

“6.5.3 If the *Contractor* is delayed in the performance of the *Work* by Force Majeure, then the Contract Time shall be extended for such reasonable time as the *Consultant* may recommend in consultation with the *Contractor*. The extension of time shall not be less than the time lost as a result of the event causing the delay, unless the *Contractor* agrees to a shorter extension. The *Contractor* shall not be entitled to payment for costs incurred by such delays unless such delays result from the actions of the Owner.”

30.3 Add new paragraphs 6.5.6, 6.5.7 and 6.5.8 as follows:

“6.5.6 If the *Contractor* is delayed in the performance of the *Work* by an act or omission of the *Contractor* or anyone employed or engaged by the *Contractor* directly or indirectly, or by any cause within the *Contractor*'s control, then the *Contract Time* shall be extended for such reasonable time as the *Consultant* may decide in consultation with the *Contractor*. The *Owner* shall be reimbursed by the *Contractor* for all reasonable costs incurred by the *Owner* as the result of such delay, including all services required by the *Owner* from the *Consultant* as a result of such delay by the *Contractor* and, in particular, the cost of the *Consultant*'s services during the period between the date of *Substantial Performance of the Work* stated in Article A-1 herein as the same may be extended through the provisions of these General Conditions and any later, actual date of *Substantial Performance of the Work* achieved by the *Contractor*.

6.5.7 The *Contractor* shall be responsible for the care, maintenance and protection of the *Work* in the event of any suspension of construction as a result of the delay described in paragraph 6.5.1, 6.5.2 or 6.5.3. In the event of such suspension, the *Contractor* shall be reimbursed by the *Owner* for the reasonable costs incurred by the *Contractor* for such protection, but excluding the costs of the *Contractor*'s head office personnel, for such care, maintenance and protection. The *Contractor*'s entitlement to costs pursuant to this paragraph 6.5.6, if any, shall be in addition to amounts, if any, to which the *Contractor* is entitled pursuant to paragraph 6.5.1, 6.5.2 or 6.5.3.

6.5.8 Without limiting the obligations of the *Contractor* described in GC3.2 or GC9.4, the *Owner* may, by notice in writing, direct the *Contractor* to stop the *Work* where the *Owner* determines that there is an imminent risk to the safety of persons or property at the Place of *Work*. In the event that the *Contractor* receives such notice, it shall immediately stop the *Work* and secure the site. The *Contractor* shall not be entitled to an extension of the Contract Time or to an increase in the *Contract Price* unless the resulting delay, if any, would entitle the *Contractor* to an extension of the Contract Time or the reimbursement of the *Contractor*'s costs as provided in paragraph 6.5.1, 6.5.2 or 6.5.3.”

31. GC 7.1 OWNER'S RIGHT TO PERFORM THE WORK, STOP THE WORK OR TERMINATE THE CONTRACT

31.1 Amend paragraph 7.1.2 by adding the words “.....fails or neglects to maintain the latest schedule provided pursuant to GC3.5...”. Immediately following the word “properly” in line one.

32. GC 7.2 CONTRACTOR'S RIGHT TO STOP THE WORK OR TERMINATE THE CONTRACT

32.1 Amend paragraph 7.2.2, in line 1, by deleting “20 *Working Days*” and replacing it with “45 days”.

32.2 Delete paragraph 7.2.3.1 and replace it with “Intentionally left blank”.

32.3 Delete paragraph 7.2.3.3 and replace it with the following:

“7.2.3.3 The *Owner* fails to pay the *Contractor* when due the amounts certified by the *Consultant* or awarded by arbitration or a Court, except where the *Owner* has a *bona fide* claim for setoff, or...”

32.4 Amend paragraph 7.2.3.4 by deleting the comma toward the end of the first line. Further amend paragraph

7.2.3.4 by deleting the phrase beginning with the word “except” and ending with the word “Owner”.

32.5 Renumber paragraph 7.2.5 as 7.2.6. Add a new paragraph 7.2.5 as follows:

“7.2.5 If the default cannot be corrected within the five *Working Days* specified in paragraph 7.2.4, the *Owner* shall be deemed to have cured the default if it:

- .1 commences correction of the default within the specified time;
- .2 provides the *Contractor* with an acceptable schedule for such correction; and
- .3 completes the correction in accordance with such schedule.

32.6 Delete renumbered paragraph 7.2.6 in its entirety and replace it with the following:

“7.2.6 If the *Contractor* terminates the Contract under the conditions described in this GC7.2, the *Contractor* shall be entitled to be paid for all *Work* performed to the date of termination. The *Contractor* shall also be entitled to recover the direct costs associated with termination, including the costs of demobilization, losses sustained on *Products* and construction machinery and equipment. The *Contractor* shall not be entitled to any recovery for any special, indirect or consequential losses.”

33. GC 8.2 NEGOTIATION, MEDIATION AND ARBITRATION

33.1 Delete GC8.2 in its entirety

34. GC 8.3 RETENTION OF RIGHTS

34.1 Delete GC 8.3 in its entirety

35. GC 9.1 PROTECTION OF WORK AND PROPERTY

35.1 Amend paragraph 9.1.1.1 by adding the following words at the end of that subparagraph: “...which the *Contractor* could not reasonably have discovered applying the standard of care described in paragraph 3.14.1;”

35.2 Add a new paragraph 9.1.5 as follows:

“9.1.5 Without in any way limiting the *Contractor’s* obligations under this GC9.1, should the *Contractor* or any Subcontractor or Supplier cause loss or damage to trees or other plantings, whether owned by the *Owner* or third parties, the *Contractor* shall be liable for the replacement cost of the trees or other plantings damaged, including the cost of any arborist or other *Consultant*, and such costs may be deducted by the *Owner* from amounts otherwise owing to the *Contractor*.”

36. GC 9.2 TOXIC AND HAZARDOUS SUBSTANCES

36.1 Add a new paragraph 9.2.5.5 as follows:

“.5 In addition to the steps described in subparagraph 9.2.5.3, take any further steps it deems necessary to mitigate or stabilize any conditions resulting from encountering toxic or hazardous substances or materials.”

36.2 Add the following to paragraph 9.2.6 after the word “responsible” in line two:

“...or whether any toxic or hazardous substances or materials already at the *Place of the Work* (and

which were then harmless or stored, contained or otherwise dealt with in accordance with legal and regulatory requirements) were dealt with by the *Contractor* or anyone for whom the *Contractor* is responsible in a manner which does not comply with legal and regulatory requirements, or which threatens human health and safety or the environment, or material damage to the property of the *Owner* or others,

- 36.3 Amend paragraph 9.2.8 by adding the following after the word “responsible” in line two:

“...or that any toxic or hazardous substances or materials already at the *Place of the Work* (and which were then harmless or stored, contained or otherwise dealt with in accordance with legal and regulatory requirements) were dealt with by the *Contractor* or anyone for whom the *Contractor* is responsible in a manner which does not comply with legal and regulatory requirements, or which threatens human health and safety or the environment, or material damage to the property of the *Owner* or others,..”

- 36.4 Add a new paragraph 9.2.10 as follows:

“9.2.10 Without limiting its other obligations under this GC9.2, the *Contractor* acknowledges that its obligations under the Contract include compliance with the Environmental Programs, including, but not limited to, the Asbestos Abatement Program. The *Contractor* acknowledges that the *Owner* may suffer loss and damage should the *Contractor* fail to comply with the Environmental Programs and agrees to indemnify and hold harmless the *Owner* with respect to any loss or damage to which the *Owner* is exposed by the *Contractor*’s failure to comply. The *Contractor* expressly agrees that such loss and damage shall be included within the scope of the *Contractor*’s indemnity described in paragraph 12.1.1 of the General Conditions. The *Contractor* acknowledges that should it fail to comply with the Environmental Program, such failure will constitute a failure to comply with the Contract to a substantial degree within the meaning of paragraph 7.1.2.”

37. GC 9.4 CONSTRUCTION SAFETY

- 37.1 Delete paragraph 9.4.1 in its entirety and replace it with the following:

“9.4.1 The *Contractor* shall be solely responsible for construction safety at the *Place of the Work* and for compliance with the rules, regulations and practices required by the applicable construction health and safety legislation and shall be responsible for initiating, maintaining and supervising all safety precautions and programs in connection with the performance of the *Work*.”

- 37.2 Add new paragraphs 9.4.2, 9.4.3 and 9.4.4 as follows:

“9.4.2 Prior to the commencement of the *Work*, the *Contractor* shall submit to the *Owner*:

- .1 a current WSIB clearance certificate;
- .2 copies of the *Contractor*’s insurance policies having application to the *Project* or certificates of insurance, at the option of the *Owner*;
- .3 documentation of the *Contractor*’s in-house safety-related programs;
- .4 a copy of the Notice of *Project* filed with the Ministry of Labour naming itself as “constructor” under OHSA.

9.4.3 The *Contractor* shall indemnify and save harmless the *Owner*, its agents, officers, directors, employees, *Consultants*, successors and assigns from and against the consequences of any and all safety infractions committed by the *Contractor* under OHSA, including the payment of legal fees and disbursements on a solicitor and client basis. Such indemnity shall apply to the extent to which the *Owner* is not covered by insurance, provided that the indemnity contained in this paragraph shall be limited to costs and damages resulting directly from such infractions and shall not extend to any consequential, indirect or special damages.

- 9.4.4 The *Owner* undertakes to include in its contracts with other contractors and/or in its instructions to its own forces the requirement that the other contractor or own forces, as the case may be, will comply with directions and instructions from the *Contractor* with respect to occupational health and safety and related matters. The text of such instruction is attached to these Supplementary Conditions as Appendix 1.”

38. GC 9.5 MOULD

- 38.1 Delete paragraph 9.5.3.3 in its entirety and replace it with the following:

“9.5.3.3 Extend the *Contract Time* for such reasonable time as the *Consultant* may recommend on consultation with the *Contractor* and the *Owner*. If, in the opinion of the *Consultant*, the *Contractor* has been delayed in performing the *Work* and/or has incurred additional costs under paragraph 9.5.1.2, the *Owner* shall reimburse the *Contractor* for the reasonable costs incurred as a result of the delay and as a result of taking those steps, and...”

39. GC 10.1 TAXES AND DUTIES

- 39.1 Amend paragraph 10.1.2 by adding the following sentence at the end of the existing paragraph:

“For greater certainty, the *Contractor* shall not be entitled to any mark up for overhead or profit on any increase in such taxes and duties and the *Owner* shall not be entitled to any credit relating to mark up for overhead or profit on any decrease in such taxes.”

- 39.2 Add new paragraphs 10.1.3, 10.1.4, 10.1.5 and 10.1.6 as follows:

“10.1.3 Where an exemption or a recovery of sales taxes, customs duties, excise taxes or Value Added Taxes is applicable to the Contract, the *Contractor* shall, at the request of the *Owner* or the *Owner's* representative, assist, join in, or make application for any exemption, recovery or refund of all such taxes and duties and all amounts recovered or exemptions obtained shall be for the sole benefit of the *Owner*. The *Contractor* agrees to endorse over the *Owner* any cheques received from the federal or provincial governments, or any other taxing authority, as may be required to give effect to this paragraph 10.1.3.

10.1.4 The *Contractor* shall maintain accurate records tabulating equipment, material and component costs reflecting the taxes, customs duties, excise taxes and Value Added Taxes paid.

10.1.5 Any refund of taxes, including without limitation, any government sales tax, customs duty, excise tax or Value Added Tax, whether or not paid, which is found to be inapplicable or for which exemption may be obtained, is the sole and exclusive property of the *Owner*. The *Contractor* agrees to cooperate with the *Owner* and to obtain from all *Subcontractors* and *Suppliers* cooperation with the *Owner* in the application for any refund of any taxes, which cooperation shall include, but not be limited to, making or concurring in the making of an application for any such refund or exemption and providing to the *Owner* copies, or where required, originals of records, invoices, purchase orders and other documentation necessary to support such applications or exemptions or refunds. All such refunds shall either be paid to the *Owner*, or shall be a credit to the *Owner* against the *Contract Price*, in the *Owner's* discretion.

10.1.6 Customs duties penalties, or any other penalty, fine or assessment levied against the *Contractor* shall not be treated as a tax or customs duty for purposes of this GC 10.1”.

40. GC 10.2 LAWS, NOTICES, PERMITS AND FEES

- 40.1 Replace GC 10.2.2 with:

"The Contractor shall obtain and pay for the building permit. The Owner shall provide and pay for all development approvals, permanent easements and rights of servitude and all other necessary approvals and permits except for the permits and fees referred to in paragraph 10.2.3 or for which the Contract Documents specify as the responsibility of the Contractor."

40.2 Amend paragraph 10.2.5 by adding the words, "Subject to paragraph 3.15.1" to the beginning of the paragraph.

40.3 Further amend paragraph 10.2.5 by adding the following to the end of the second sentence:

"...and no further *Work* on the affected components of the Contract shall proceed until these changes to the *Contract Documents* have been obtained by the *Contractor* from the *Consultant*."

40.4 Further amend paragraph 10.2.5 by adding the following sentence to the end of the paragraph, as amended:

"The *Contractor* shall notify the Chief Building Official or the registered code agency where applicable, of the readiness, substantial completion, and completion of the stages of construction set out in the Ontario Building Code. The *Contractor* shall be present at each site inspection by an inspector or registered code agency as applicable under the Ontario Building Code."

40.5 Amend paragraph 10.2.6 by adding the following sentence at the end of that paragraph:

"In the event the *Owner* suffers loss or damage as a result of the *Contractor's* failure to comply with paragraph 10.2.5, and notwithstanding any limitations described in paragraph 12.1.1, the *Contractor* agrees to indemnify and to hold harmless the *Owner* and the *Consultant* from and against any claims, demands, losses, costs, damages, actions, suits or proceedings resulting from such failure by the *Contractor*."

41. GC 10.4 WORKERS' COMPENSATION

41.1 Amend paragraph 10.4.1 so that, as amended, it reads as follows:

"Prior to commencing the *Work*, and with each application for payment thereafter, the *Contractor* shall provide a Clearance Certificate from WSIB."

42. GC 11.1 INSURANCE

42.1 Add the following to 11.1.1.1:

"General liability insurance shall be with limits of not less than \$5,000,000 per occurrence, an aggregate limit of not less than \$5,000,000 within any policy year with respect to completed operations, and a deductible not exceeding \$5,000. The insurance coverage shall not be less than the insurance provided by IBC Form 2100 (including an extension for a standard provincial and territorial form of non-owned automobile liability policy) and IBC Form 2320. To achieve the desired limit, umbrella or excess liability insurance may be used. Subject to satisfactory proof of financial capability by the *Contractor*, the *Owner* may agree to increase the deductible amounts.

42.2 Add the following to 11.1.1.2:

Automobile liability insurance in respect of vehicles that are required by law to be insured under a contract by a Motor Vehicle Liability Policy, shall have limits of not less than \$5,000,000 inclusive per occurrence for bodily injury, death and damage to property, covering all vehicles owned or leased by the *Contractor*. Where the policy has been issued pursuant to a government-operated automobile insurance system, the *Contractor* shall provide the *Owner* with confirmation of automobile insurance coverage for all automobiles registered in the name of the *Contractor*.

42.3 Add the following to 11.1.1.4:

"Broad form" property insurance shall have limits of not less than the sum of 1.1 times *Contract Price* and the full value, as stated in the *Contract*, of *Products* and design services that are specified to be provided by the *Owner* for incorporation into the *Work*, with a deductible not exceeding \$5,000. The insurance coverage shall not be less than the insurance provided by IBC Forms 4042 and 4047 (excluding flood and earthquake) or their equivalent replacement. Subject to satisfactory proof of financial capability by the *Contractor*, the *Owner* may agree to increase the deductible amounts.

- 42.4 Add the following to 11.1.1.5:

Boiler and machinery insurance shall have limits of not less than the replacement value of the permanent or temporary boilers and pressure vessels, and other insurable objects forming part of the *Work*. The insurance coverage shall not be less than the insurance provided by a comprehensive boiler and machinery policy.

- 42.5 Add the following to 11.1.1.6:

"Broad form" contractors' equipment insurance coverage covering *Construction Equipment* used by the *Contractor* for the performance of the *Work*, shall be in a form acceptable to the *Owner* and shall not allow subrogation claims by the insurer against the *Owner*. Subject to satisfactory proof of financial capability by the *Contractor* for self-insurance, the *Owner* may agree to waive the equipment insurance requirement.

43. GC 11.2 CONTRACT SECURITY

- 43.1 Delete paragraphs 11.2.1 and 11.2.2 in their entirety and replace them with the following:

"11.2.1 Subject to paragraph 11.2.4, the *Contractor* shall furnish a performance bond in favour of the *Owner*, covering the faithful performance of the *Contract*, including the payment obligations arising there under, made upon the contract bond form of the *Owner* and issued by such surety company(ies) as the *Owner* may approve. The bond shall be for one hundred per cent (50%) of the *Contract Price* or such other amount as may be specified in the *Contract Documents*.

11.2.2 The *Contractor* shall furnish a labour and material payment bond in favour of the *Owner* in a form satisfactory to the *Owner* and issued by such surety company(ies) the *Owner* may approve. The bond shall be for one hundred per cent (50%) of the *Contract Price*.

11.2.3 It is the intention of the *Contract* that the performance bond shall be applicable to all of the *Contractor's* obligations under this *Contract* and, wherever a performance bond is provided with language which conflicts with this intention, it shall be deemed to be amended to comply. The *Contractor* represents and warrants that it has provided its surety with a copy of the *Contract* prior to the issuance of such bonds.

11.2.4 Where the *Contract Price*, arising from the *Owner's* award of the *Contract*, includes Subcontractor default insurance in lieu of a performance bond, the *Contractor* shall deliver to the *Owner* a certified copy of the policy of Subcontractor default insurance. Such policy shall have an aggregate loss limit of not less than 50% of the *Contract Price* and a claim limit of not less than 50% of such *Contract Price*. Such policy of insurance shall be subject to the approval of the *Owner*, acting reasonably, as to the terms and conditions of the Subcontractor default insurance, including those described in this paragraph 11.2.4."

44. GC 12.1 INDEMNIFICATION

- 44.1 Delete paragraphs 12.1.1 through 12.1.6 in their entirety and replace them with the following:

"12.1.1 The *Contractor* shall indemnify and hold harmless the *Owner* and the *Consultant*, their agents, employees and assigns from and against all claims, demands, damages, losses, expenses, costs, including legal fees, actions, suits or proceedings by whomsoever made,

brought or prosecuted in any manner, arising out of, resulting from or attributable to the *Contractor's* or any Subcontractor's performance or non-performance of the Contract, regardless of whether or not caused in part by a party indemnified hereunder. It is expressly understood that the *Contractor* will save harmless the *Owner* from all claims made by any party other than the *Contractor* itself, financial or otherwise, relating to labour and materials furnished by the *Contractor* or by others for the *Work*.

- 12.1.2 It is the intention of the parties that the *Consultant*, its officers, agents, partners, employees, directors and insurers, as well as any *Subconsultants*, or other *Consultants* retained with respect to the *Project*, and their officers, agents, partners, employees, directors and insurers, is to benefit from the indemnification and hold harmless provisions of paragraph 12.1.1.
- 12.1.3 The *Owner* shall indemnify and hold harmless the *Contractor*, his agents and employees from and against claims, demands, losses, costs, damages, actions, suits or proceedings arising out of the *Contractor's* performance of the Contract which are attributable to a lack of or defect in title or an alleged lack of or defect in title to the *Place of the Work*.
- 12.1.4 Notwithstanding the provisions of GC1.1 -*CONTRACT DOCUMENTS*, paragraph 1.1.7, GC12.1 - INDEMNIFICATION shall govern over the provisions of paragraph 1.3.1 of GC1.3 – RIGHTS AND REMEDIES.”

45. GC 12.2 WAIVER OF CLAIMS

45.1 Delete paragraphs 12.2.1 through 12.2.10 and replace them with the following:

“12.2.1 As of the date of the final certificate for payment, the *Owner* expressly waives and releases the *Contractor* from all claims against the *Contractor* including without limitation those that might arise from negligence or breach of contract by the *Contractor* except for one or more of the following:

- .1 those made in writing prior to the date of the final certificate for payment and still unsettled;
- .2 those arising from the provisions of GC12.1 – INDEMNIFICATION or GC12.3 – WARRANTY;
- .3 those arising from GC9.2 – TOXIC AND HAZARDOUS SUBSTANCES AND MATERIALS and arising from the *Contractor* bringing or introducing any toxic or hazardous substances and materials to the *Place of the Work* after the *Contractor* commences the *Work*;
- .4 those made by Notice in Writing within a period of six years from the date of *Substantial Performance of the Work* as set out in the certificate of substantial performance, or within such shorter period as may be prescribed in any limitation statute of the province or territory of the *Place of the Work* and arising from any liability of the *Contractor* for damages resulting from the *Contractor's* performance of the *Contract* with respect to substantial defects or deficiencies in the *Work* for which the *Contractor* is proven responsible. As used herein, “substantial defects or deficiencies” means those defects or deficiencies in the *Work* where the reasonable cost of repair of such defects or deficiencies exceeds:
 - .1 for a *Contract Price* of \$2,000,000 or less, the sum of \$50,000, before HST;

12.2.2 As of the date of certificate of *Substantial Performance of the Work*, the *Contractor* expressly waives and releases the *Owner* from all claims which it has or reasonably ought to have knowledge of that could be advanced against the *Owner* including without limitation those that might arise from the negligence or breach of contract by the *Owner* except:

- .1 those made in writing prior to the *Contractor's* application for final payment and still unsettled; and

- .2 those arising from the provisions of GC9.2 – TOXIC AND HAZARDOUS SUBSTANCES AND MATERIALS or GC10.3 – PATENT FEES.”

46. GC 12.3 WARRANTY

46.1 Revise paragraph 12.3.1 by replacing the words “one year” with “two years”.

46.2 Amend paragraph 12.3.1 by adding the following sentence at the end of that paragraph:

“Where the *Contractor* has been permitted to make use of permanent equipment or systems, as provided in GC3.16, prior to the issuance of the certificate of Substantial Performance of the *Work*, such permanent equipment or system shall be subject to the same warranty as described in this GC12.3 and shall be judged, for purposes of assessing compliance with the warranty, as though the equipment or system was new, clean and unused by the *Contractor*, except for normal commissioning and startup activities, prior to the date of Substantial Performance of the *Work*.”

46.3 Delete the present text of 12.3.2 and substitute the following:

“The Contractor expressly warrants and guarantees to the Owner that the Work performed by the Contractor and by all Workers, Suppliers and Subcontractors conforms to the requirements of the Contract Documents and is performed in a safe and careful manner.”

46.4 Revise paragraph 12.3.3 by replacing the words “one year” with “two years”.

46.5 To paragraph 12.3.4 add new sentence:

“The warranty period shall commence for corrected Work.”

46.6 To paragraph 12.3.4 add new sentence:

“Except for extended warranties provided under this contract, the warranty period shall recommence for corrected Work.”

46.7 Delete the present text of paragraph 12.3.5 and substitute the following:

“12.3.5 The Contractor shall correct or pay for all damages to the Work and/or property, goods or equipment of the Owner and/or his tenants and neighbouring properties, resulting from the defects, deficiencies or corrections of the same.”

46.8 Revise paragraph 12.3.6 by replacing the words “one year” with “two years”.

46.9 Add a new paragraph 12.3.7 as follows:

“12.3.7 The Contractor shall commence to correct any deficiency within five (5) Working Days after consultant or Owner, issuance a notice from the Consultant or Owner and complete the Work as expeditiously as possible, except that in the case of urgent repairs, where the deficiency would prevent maintaining security or operating, as designed, of basic systems essential to the ongoing business of the Owner, all necessary corrections and/or installations or temporary replacements shall be carried out immediately as an emergency service. Should the Contractor fail to provide this emergency service within two (2) hours of a notification, the Owner is authorized, irrespective of the conditions of GC 7.1, to carry out all necessary repairs or replacements at the Contractor’s expense.

46.10 Add a new paragraph 12.3.8 as follows:

“12.3.8 The *Contractor* shall assign to the *Owner* all warranties, guarantees or other obligations for *Work*, services or *Products* performed or supplied by any Subcontractor, Supplier or other person in

connection with the *Work* and such assignment shall be with the consent of the assigning party where required by law or by the terms of that party's contract. Such assignment shall be in addition to, and shall in no way limit, the warranty rights of the *Owner* under the *Contract Documents*. Until the expiry of the relevant warranty periods enforceable against the *Contractor*, the *Owner* shall have in its custody all warranties, guarantees and other obligations to third parties respecting the *Work*."

47. PART 13 – OTHER PROVISIONS

47.1 Add GC 13.1 OWNERSHIP OF MATERIALS as follows:

"13.1 Unless otherwise specified, all materials existing at the *Place of the Work* at the time of execution of the Contract shall remain the property of the *Owner*. All *Work*, *Products* and materials delivered by the *Contractor* which form part of the *Work* shall be considered the property of the *Owner* but the *Contractor* shall remove all surplus or rejected materials as its property when notified in writing to do so by the *Consultant*."

47.2 Add GC13.2 CONTRACTOR DISCHARGE OF LIABILITIES as follows:

"13.2.1 In addition to the obligations assumed by the *Contractor* pursuant to GC3.7, the *Contractor* agrees to discharge all liabilities incurred by it for labour, materials, services, *Subcontractors* and *Products*, used or reasonably required for use in the performance of the *Work*, on the date upon which each such liability becomes due.

13.2.2 The *Contractor* shall cause every *Subcontractor* and *Supplier* engaged in the performance of the *Work* to discharge all liabilities incurred by them for labour, materials, services and *Products* used or reasonably required for use in the performance of the *Work*. *Workmen* employed by a *Subcontractor* or *Supplier* shall be paid in full at intervals not less frequently than required by the governing law and all liabilities of the *Subcontractors* and *Suppliers* shall be discharged on the date upon which each becomes due. At the request of the *Owner*, the *Contractor* shall furnish the *Owner* with satisfactory evidence that its liabilities and those of its *Subcontractors* and *Suppliers* have been discharged."

47.3 Add GC 13.3 AS-BUILT OR RECORD DRAWINGS as follows:

"13.3 Unless otherwise provided in the *Contract Documents*, the *Contractor* shall prepare as-built or record drawings and provide them to the *Consultant* for review."

47.4 Add GC 13.4 DAILY REPORTS/DAILY LOGS as follows:

"13.4.1 The *Contractor* shall cause its supervisor, or such competent person as he or she may delegate, to prepare a daily log or diary reporting on weather conditions, *work force* of the *Contractor*, *Subcontractors*, *Suppliers* and any other forces on site and also record the general nature of *Project* activities. Such log or diary shall also include any extraordinary or emergency events which may occur and also the identities of any persons who visit the site who are not part of the day-to-day *work force*.

13.4.2 The *Contractor* shall also maintain records, either at its head office or at the job site, recording manpower and material resourcing on the *Project*, including records which document the activities of the *Contractor* in connection with GC3.5, and comparing that resourcing to the resourcing anticipated when the most recent version of the schedule was prepared pursuant to GC3.5.

13.4.3 Upon request by the *Owner* or the *Consultant*, the *Contractor* shall make available for inspection and copying all of the records generated pursuant to this GC13.4 along with any other routine *Project* records ordinarily maintained by the *Contractor*."

47.5 Add GC 13.5 CONSTRUCTION LIENS as follows:

"13.5 In the event that any construction lien is registered against the *Project* by or through a *Subcontractor* or *Supplier*, and provided the *Owner* has paid all amounts properly due under the *Contract*, and has otherwise complied with its material obligations under the *Contract*, the *Contractor* shall, at its own expense, post the security necessary to vacate or discharge such lien, as the case may be. In the event that a lien action is commenced and a Statement of Claim is issued and served, the *Contractor* shall take all reasonable steps to remove the *Owner* from the main action and to indemnify it and hold it harmless in such action, except where the Statement of Claim makes substantial claims against the *Owner* beyond the recovery of holdback under the *Act*."

47.6 Add GC13.6 NEUTRAL APPOINTING AUTHORITY

"13.6.1 For purposes of the Rules for Mediation and Arbitration of Construction Disputes CCDC 40, the term "neutral appointing authority", as used in both the Rules for Mediation of CCDC2 Construction Disputes and the Rules for Arbitration of CCDC2 Construction Disputes shall mean the "Appointing Committee" at ADR Chambers presiding at the time notice of the dispute is given pursuant to the *Contract*."

47.7 Add GC13.7 FREEDOM OF INFORMATION AND PROTECTION OF PRIVACY ACT:

"13.7.1 Throughout the term of this *Contract*, and for a period of seven years thereafter, the *Owner* and the *Contractor* will protect the confidentiality of all proprietary and confidential information of the other that is disclosed to it and will protect such information with the same standard of care as such party would use to protect the confidentiality of its own proprietary and confidential information which shall be, at a minimum, a reasonable standard, and, in any event, each party shall protect the confidentiality of all such proprietary and confidential information as may be required by law, including, without limitation, as may be required under the *Freedom of Information and Protection of Privacy Act*.

13.7.2 Notwithstanding the obligations of the *Owner* described in paragraph 13.7.1, the *Contractor* acknowledges that the *Owner* is subject to the *Freedom of Information and Protection of Privacy Act*, as amended, and may be required to release, in whole or in part, this *Contract* and any other documents or information in the *Owner's* possession or control that relate to this *Contract*."

END OF SECTION 00800

1.1. DOCUMENTS REQUIRED

1. Maintain at job site, one copy each of the following:
 1. Contract drawings.
 2. Specification.
 3. Addenda.
 4. Reviewed shop drawings.
 5. Change orders.
 6. Other modifications to Contract.
 7. Field test reports.
 8. Copy of approved work schedule.
 9. Manufacturer's installation and application instructions.
 10. Standards listed in Part 1 of Specification Sections under Reference Standards.

1.2. PRODUCTS SUPPLIED BY CONSULTANT

1. Promptly inspect delivered products, and provide written report to Consultant on condition of all items received.
2. Install, connect and finish products specified.

1.3. WORK SCHEDULE

1. In accordance with schedule and in form acceptable to Consultant, provide within five working days after Contract award, schedule showing dates for:
 1. Submission of shop drawings, material lists and samples.
 2. Delivery of all equipment and materials.

1.4. APPLICATION FOR PAYMENT

1. Payments on this Contract to be made by the Owner in accordance with Supplementary General GC-5.2 - Application for Progress Payment.
2. The breakdown shall include a separate line item with a value of \$1,000.00 as a deposit for borrowed keys. This line item will not be paid until Total Completion of the project has been achieved and the Owner's Designee has confirmed that all borrowed keys have been returned. If keys are not returned within 30 days after Total Completion, the Contractor forfeits the deposit to the Owner who will utilize these funds for re-keying of the building.

3. Holdback procedure shall be in accordance with Construction Lien Act R.S.O. 1990 c. C30.
4. Payment will be made by the Owner to the Contractor by electronic fund transfer (EFT/direct deposit) method only.

1.5. CONTRACTOR'S USE OF SITE

1. Contractor shall use access to building as indicated by the Owners.
2. Storage areas are to be identified by the School during construction period.
3. Do not unreasonably encumber site with materials or equipment.
4. Move stored products or equipment which interfere with operations of Consultant or other contractors.
5. Obtain and pay for use of additional storage or work areas needed for operations.

1.6. CODES AND STANDARDS

1. Perform work in accordance with the latest additions of the Ontario Building Code 2012 and any other code of provincial or local application provided that in any case of conflict or discrepancy, the more stringent requirements shall apply.
2. Meet or exceed requirements of contract documents, codes and referenced documents.

1.7. PROJECT MEETINGS

1. Consultants will arrange project meetings and assume responsibility for setting times and recording and distributing minutes.

1.8. LOCATION OF EQUIPMENT AND FIXTURES

1. Location of equipment indicated or specified is to be considered as approximate.
2. Locate equipment in accordance with manufacturer's recommendations for safety, access and maintenance.
3. Inform consultant of impending installation and obtain his approval for actual location.
4. Submit field drawings to indicate relative position of various services and equipment when required by Consultant.

1.9. CONCEALMENT

1. Conceal conduit, and wiring in floor, wall and ceiling construction of finished areas except where indicated otherwise.

1.10. CUTTING, FITTING, AND PATCHING

1. Execute cutting, fitting and patching required to make work fit properly.
2. Where new work connects with existing and where existing work is altered, cut, patch and make good to match existing work.
3. Obtain Consultant's approval before cutting, boring and sleeving load bearing members.
4. Make cuts with clean, true, smooth edges. Make patches inconspicuous in final assembly.

1.11. EXISTING SERVICES

1. Where work involves breaking into or connecting to existing services, carry out work at times directed by Owners with minimum of disturbance to occupants.
2. Before commencing work, establish location and extent of service lines in area of work and notify Consultant of findings.
3. Submit schedule to and obtain approval from Consultant for any shut down or closure of active service or facility. Adhere to approved schedule and provide notice to affected parties.
4. Where unknown services are encountered, immediately advise Consultant and confirm findings in writing.

1.12. ALTERATIONS, ADDITIONS OR REPAIRS TO EXISTING BUILDING

1. Execute Work with least possible interference or disturbance to occupants, public and normal use of premises. Arrange with Consultant to facilitate execution of work.

1.13. ADDITIONAL DRAWINGS

1. Consultant may furnish additional drawings to assist proper execution of work. These drawings will be listed issued for clarification only. Such drawings shall have same meaning and intent as if they were included with plans referred to in contract documents.

1.14. BUILDING PERMIT

1. Apply for building/plumbing permit at local Building Department. The Contractor shall obtain and pay for the building permit. Include all costs in the tender price. Consultant will provide two sets of contract documents at cost

1.15. BUILDING SMOKING ENVIRONMENT

1. Comply with smoking restrictions.

END OF SECTION 01005

1.1. REQUIREMENTS INCLUDED

1. Shop drawings and product data.
2. Samples.
3. Operating and maintenance manuals.
4. Record drawings.
5. Certificates of transcripts.

1.2. ADMINISTRATIVE

1. Submit to Consultant submittals listed for review. Submit with reasonable promptness and in an orderly sequence so as to not cause delay in Work. Failure to submit in ample time is not considered sufficient reason for an extension of Contract Time and no claim for extension by reason of such default will be allowed.
2. Work affected by the submittal shall not proceed until review is complete.
3. Review submittals prior to submission to the Consultant. This review represents that necessary requirements have been determined and verified, or will be, and that each submittal has been checked and coordinated with requirements of the Work and the Contract Documents. Submittals not stamped, signed, dated and identified as the specified project will be returned without being examined and shall be considered rejected.
4. Verify field measurements and affected adjacent Work are coordinated.
5. Contractor's responsibility for errors and omissions in submission is not relieved by Consultant review of submittals.
6. Contractor's responsibility for deviations in submission from requirements of Contract Documents is not relieved by Consultant review.
7. Keep one reviewed copy of each submission on site.

1.3. SHOP DRAWINGS AND PRODUCT DATA

1. Refer to GC 3.10.
2. The term "Shop Drawings" means drawings, diagrams, illustrations, schedules, performance charts, brochures and other data which are to be provided by the Contractor to illustrate details of a portion of the Work.
3. Indicate materials, methods of construction and attachment or anchorage, erection diagrams, connections, explanatory notes and other information necessary for completion of Work. Where articles or equipment attach or connect to other articles or equipment, indicate that such items have been coordinated, regardless of the Section under which the adjacent items

will be supplied and installed. Indicate cross references to design drawings and specifications.

4. Adjustments made on shop drawings by the Consultant are not intended to change the Contract Price. If adjustments affect the value or Work, state such in writing to the Consultant prior to proceeding with the Work.
5. Make changes in shop drawings as the Consultant may require, consistent with Contract Documents. When resubmitting, notify the Consultant in writing of any revisions other than those requested.
6. Submit photocopies of shop drawings for each requirement requested in Specification Sections and as the Consultant may reasonably request.
7. Submit one 'PDF' format of product data sheets or brochures for requirements requested in specification Sections and as the Consultant may reasonably request where shop drawings will not be prepared due to standardized manufacture of product.
8. If upon review by the Consultant, no errors or omissions are discovered or if only minor corrections are made, 'PDF' copies will be returned and fabrication and installation of Work may proceed. If shop drawings are rejected, noted copy will be returned and resubmission of corrected shop drawings, through the same procedure indicated above, shall be performed before fabrication and installation of Work may proceed.

1.4. OPERATING MAINTENANCE MANUALS

1. Two weeks prior to Substantial Performance of the Work, submit to the Consultant one (1) copy of operating and maintenance manuals and As-Built Drawings and 'PDF' copy on USB stick.
2. Manual to contain operational information on equipment, cleaning schedules, and similar maintenance information. Instructions in this manual shall be in simple language so as to guide the Owner in the proper operation and maintenance of building components.
3. Bind contents in a three-ring, hard covered, plastic jacketed binder as well as in PDF format on USB stick. Organize contents into applicable categories of work, parallel to specification Sections.
4. In addition to information specified, include the following:
 1. Title sheet, labelled "Operating and Maintenance Instructions", containing project name and date.
 2. List of names, addresses and phone numbers of subcontractors and suppliers who can affect repair or maintenance on equipment.
 3. List of contents.
 4. Final shop drawings and product data of equipment.
 5. Record drawings of electrical installation.

6. Full description of building systems and operation.

1.5. RECORD DRAWINGS

1. After award of Contract the Consultant will provide one (1) set of white prints for the purpose of maintaining record drawings (at cost). Accurately, neatly record deviations from Contract Documents caused by site conditions and changes ordered by the Consultants. Make changes in red ink.
2. Record locations of concealed components of mechanical and electrical services.
3. Identify drawings as "Project Record Copy". Maintain in new condition and make available for inspection on site by Consultant.
4. On completion of Work and prior to final inspection, submit two copies of record documents to Consultant.

1.6. CERTIFICATE AND TRANSCRIPTS

1. After award of Contract, submit WSIB status transcription of insurance.

END OF SECTION 01300

1.1. REQUIREMENTS INCLUDED

1. Inspection and testing, administrative and enforcement requirements.
2. Tests.
3. Testing of all Heating Plant operation.

1.2. RELATED REQUIREMENTS

1. Section 01300: Submission of shop drawings to confirm product quality.

1.3. INSPECTION

1. Refer to GC 2.3.
2. The Owner and the Consultant shall have access to the Work.
3. Give timely notice requesting inspection if work is designated for special tests, inspections or approvals by Consultant instructions, or the law of the Place of the Work.
4. If the Contractor covers or permits to be covered work that has been designated for special tests, inspections or approvals before such is made, uncover such work, have the inspections or tests satisfactorily completed and make good such work.
5. The Consultant may offer any part of the work to be examined if such work is suspected to be not in accordance with the Contract Documents, correct such work and pay the cost of examination and correction. If such work is found in accordance with the Contract Documents, the Owner will pay the cost of examination and replacement.

1.4. PROCEDURES

1. Notify the appropriate agency and Consultant in advance of the requirements for tests, in order that attendance arrangements can be made.

1.5. REJECTED WORK

1. Remove defective work, whether the result of poor workmanship, use of defective products or damage and whether incorporated in the work or not, which has been rejected by the consultant as failing to conform to the Contract documents. Replace or re-execute in accordance with the Contract Documents.
2. Make good other Contractors work damaged by such removals or replacements promptly.
3. If in the opinion of the Consultant it is not expedient to correct defective work or work not performed in accordance with the Contract Documents, the Owner may deduct from the Contract Price the difference in value between the Work performed and that called for by the

Contract Documents, the amount of which shall be determined by the Consultant.

1.6. REPORTS

1. Submit final test report confirming operation and system function.

END OF SECTION 01400

1.1. CONSTRUCTION SAFETY MEASURES

1. Observe and enforce construction on safety measures required by Ontario Building Code 2012, Provincial Government, WSIB, and Municipal Statutes and authorities.
2. In event of conflict between any provisions of above authorities the most stringent provision governs.

1.2. FIRE SAFETY REQUIREMENTS

1. Comply with requirements of Ontario Fire Marshal's Office.
2. All Contractor superintendents shall be briefed by the Owner on Facilities fire safety program.

END OF SECTION 01545

1.1. REQUIREMENTS INCLUDED

1. Reference standards.
2. Product quality, availability, storage, handling, protection, transportation.
3. Manufacturer's instructions.
4. Workmanship, co-ordination, cutting, fastenings.
5. Existing facilities.

1.2. REFERENCE STANDARDS

1. Within the text of the specifications reference may be made to the following standards:
 1. ANSI - American National Standards Institute
 2. ASTM - Americana Society of Testing and Materials
 3. OESC - Ontario Electrical Safety Code
 4. CEMA - Canadian Electrical Manufacturers Association
 5. CGSB - Canadian General Standards Board
 6. CPCA - Canadian painting Contractors Association
 7. CSA - Canadian Standards Association
 8. IEEE - Institute of Electrical and Electronic Engineers
 9. IPCEA - Insulated Power Cable Engineers Association
 10. OBC - Ontario Building Code 2012
 11. ULC - Underwriters Laboratories of Canada.
2. Conform to these standards, in whole or in part, as specifically requested in the specifications.
3. If there is questions as to whether any product or system is in conformance with applicable standards, the Consultants reserves the right to have such products or systems tested to prove or disprove conformance.
4. Conform to latest date of issue of reference standards effect on date of submission of bids except where a specific date or issue is specifically noted.

1.3. PRODUCTS AND MATERIALS

1. Quality:
 1. Products, materials, equipment and articles (referred to as Products throughout the specifications) incorporated in the Work shall be new, not damaged or defective, and of the best quality (compatible with specifications) for the purpose intended. If required, furnish evidence as to type, source and quality of Products provided.
 2. Defective products, whenever identified prior to the completion of Work, will be rejected, regardless of previous inspections. Inspection does not relieve responsibility, but it is a precaution against oversight or error. Remove and replace defective products at own expense and be responsible for delays and expenses caused by rejection.
 3. Should any dispute arise as to the quality of fitness of products, the decision rests strictly with the Consultant based upon the requirements of the Contract Documents.
 4. Unless otherwise indicated in the specifications, maintain uniformity of manufacture for any particular or like item throughout the building.
 5. Permanent labels, trademarks, and nameplates on Products are not acceptable in prominent locations, except where required for operating instructions, or when located in mechanical or electrical rooms.
2. Transportation
 1. Pay costs of transportation of Products required in the performance of Work.

1.4. MANUFACTURER'S INSTRUCTIONS

1. Unless otherwise indicated in the specifications, install or erect products in accordance with manufacturer's instructions. Do not rely on labels or enclosures provided with products. Obtain written instructions directly from manufacturers.
2. Notify the consultant in writing of conflicts between the specifications and manufacturers instructions, so that the Consultant may establish the course of action.
3. Improper installation or erection of Products, due to failure in complying with these requirements, authorizes the Consultant to require removal and re-installation at no increase in Contract Price.

1.5. WORKMANSHIP

1. General
 1. Workmanship shall be the best quality, executed by workers experienced and skilled in the respective duties for which they are employed. Immediately notify the Consultant if required work is such as to make it impractical to produce required results.
 2. Do not employ any unfit person or anyone unskilled in their required duties. The Consultant reserves the right to require the dismissal from the site, workers deemed incompetent, careless, insubordinate or otherwise objectionable.

3. Decisions as to the quality of fitness of workmanship in cases of dispute rest solely with the Consultant whose decision is final.
2. Location of Devices
 1. Consider the location of devices indicated as approximate.
 2. Inform the Consultant of a conflicting installation. Install as directed.
3. Fastenings
 1. Provide metal fastenings and accessories in same textures, colour and finish as adjacent materials, unless indicated otherwise.
 2. Prevent electrolytic action between dissimilar metals and materials.
 3. Use noncorrosive hot dip galvanized steel fasteners and anchors for securing exterior work, unless stainless steel or other material is specifically requested in the affected specification Section.
4. Protection of Work in Progress.
 1. Adequately protect Work completed or in progress. Work damaged or defaced due to failure in providing such protection is to be removed and replaced, or repaired, as directed by the Consultant Price.
5. Existing Utilities
 1. When breaking into or connecting to existing services or utilities, execute work at times directed by owner with a minimum of disturbance of work, and/or building occupants.
 2. Protect, relocate and maintain existing active services. When inactive services are encountered, cap off in a manner approved by authority having jurisdiction and stake or otherwise record location of capped service.

END OF SECTION 01600

1.1. REQUIREMENTS INCLUDED

1. Final cleaning.
2. Systems demonstration.
3. Document submission.
4. Project commissioning.
5. Inspection and takeover procedures.

1.2. RELATED REQUIREMENTS

1. Section 01300: Submission of record drawings.
2. Section 01300: Operating/maintenance manuals.
3. General Conditions of the Contract: Fiscal provisions, legal submittal and other administrative requirements.

1.3. FINAL CLEANING

1. Refer to GC 3.13.
2. When the Work is Substantially Performed, remove surplus products, tools, construction machinery and equipment not required for the performance of the remaining Work.
3. Remove waste products and debris other than that caused by the Owner, other contractors or their employees, and leave the Work clean and suitable for occupancy by Owner.
4. When the Work is Totally Performed, remove surplus products, tools, construction machinery and equipment. Remove waste products and debris other than that caused by the Owner or other Contractors.
5. Remove waste materials and debris from the site at regularly scheduled times or dispose of as directed by the Consultant. Do not burn waste materials on site.
6. Make arrangements with and obtain permits from authorities having jurisdiction for disposal of waste and debris.
7. Remove stains, spots, marks and dirt from mechanical equipment and electrical panels.
8. Inspect finishes, fitments and equipment and ensure specified workmanship and operation.
9. Clean equipment to a sanitary condition.

1.4. SYSTEMS DEMONSTRATION

1. Prior to final inspection, demonstrate operation of each system to Owner and Consultant.
2. Instruct personnel in operation, adjustment, and maintenance of equipment and systems, using provided operation and maintenance data as the basis for instruction.

1.5. DOCUMENTS

1. Collect reviewed submittals (Section 01300) and assemble documents executed by Subcontractors, suppliers, and manufacturers.
2. Submit material prior to final Application for Payment. For equipment put into use with Owner's permission during construction, submit within 10 days after start-up. For items of Work delayed materially beyond date of Substantial Completion, provide updated submittal within ten days after acceptance, listing date of acceptance as start of warranty period.
3. Provide warranties fully executed and notarized – min. 1 year.
4. Execute transition of Performance and Labour and Materials Payment Bond to warranty period requirements.
5. Submit final statement of accounting giving total adjusted Contract Sum, previous payments, and monies remaining due.
6. Consultant will issue a final change order reflecting approved adjustments to Contract Sum not previously made.

1.6. PROJECT COMMISSIONING

1. Expedite and complete deficiencies and defects identified by the Consultant.
2. Review maintenance manual contents, operating, maintenance instructions, record "as-built" drawings, spare parts, materials for completeness.
3. Submit required documentation such as statutory declarations, Worker's Compensation Certificates, warranties, certificates of approval or acceptance from regulating bodies.
4. Review inspection and testing reports to verify conformance to the intent of the documents and that changes, repairs or replacements have been completed.
5. Co-ordinate Owner's mocking-in of staff, furnishings, equipment with building accessibility, and contractor's and Subcontractor's cleaning-up and completion activities all to suit Owner's work schedule and not disrupt Owner's productivity.
6. Provide on-going review, inspection and attendance to building call-back, maintenance and repair problems during Warranty periods.

1.7. INSPECTION/TAKEOVER PROCEDURES

1. Prior to application for certificate of Substantial Performance, carefully inspect the Work and

ensure it is complete, that major and minor construction deficiencies are complete and/or corrected and the building is clean and in condition for occupancy. Notify the Consultant in writing, of satisfactory completion of the Work and request an inspection.

2. During the Consultant inspection, a list of deficiencies and defects will be tabulated. Correct same.
3. When the Consultant considers deficiencies and defects have been corrected and it appears requirements of the Contract have been performed, make application for certificate of Substantial Performance. Refer to General Conditions Article GC 5.4 for specifics to application.

END OF SECTION 01700

PART 1- GENERAL

1.1. GENERAL

1. This section covers items common to all sections of Division 15 and is supplementary to requirements of Division 1.
2. Division 1, General Requirements is part of this Section and shall apply as if repeated here.
3. Coordinate all requirements with General Contractor.

1.2. CODE OF STANDARDS

1. Do complete installation in compliance with latest editions and all amendments of the following Codes and Standards. Where conflicts in requirements occur, the higher standard shall apply:
 1. ASHRAE
 2. SMACNA
 3. CSA
 4. Ontario Building Code
 5. All governing municipal requirements
 6. ULC
 7. LEED Canada for New Construction and Major Renovations 2009.

1.3. DEFINITIONS

1. "Provide" means supply and install.
2. "Approved" means approved in writing by Consultant.
3. "Consultant" means designated qualified professional engineer acting as representative of Owner for monitoring of work.
4. "Manual" means Operations and Maintenance manual.

1.4. CARE, OPERATION, START-UP AND INSTRUCTION TO OWNERS

1. Provide certified personnel to instruct Owner of operation mechanical equipment. Provide maintenance specialist personnel to instruct on maintenance and adjustment of mechanical equipment and any changes or modification equipment must be under terms of guarantee.

2. Provide instruction during regular work hours prior to acceptance and turn over to Owner's staff for regular operation.
3. Provide these services for such period, and for as many visits as necessary to put equipment in operation, and ensure that operating personnel are conversant with all aspects of its care and operation.
4. Use operation and maintenance data manual for instruction purposes. On completion of instruction, turn three manuals over to the Owner.
5. Operation and maintenance manual to be approved by and final copies deposited with Consultant before final inspection.
6. Arrange and pay for services of manufacturer's factory service engineer to supervise start-up of installation, check, adjust, balance and calibrate components and instruct operating personnel.

1.5. PERMITS, CERTIFICATES, FEES AND INSPECTIONS

1. Submit to the Building Department the necessary number of drawings and specifications for examination prior to commencement of work to obtain a building/plumbing permit. Obtain and pay for all building/plumbing permits. Include all costs in the tender price.
2. Submit Notice of Project to Ministry of Labour.
3. Contractor shall be responsible to pay associated fees.
4. Notify Consultant of changes required by Building Department prior to making changes.
5. Notify Consultant upon completion of work.

1.6. COORDINATION WITH EXISTING UTILITIES

1. Before commencing any Work, the Contractor shall determine the locations of all underground utilities and structures indicated in or inferable from the Contract Documents, or that are inferable from an inspection of the Place of the Work.
2. All existing utilities are to be maintained and protected for the length of construction.
3. Contractor to notify consultant if any conflicts arise and allow for minimum 48 hours for consultants review.

1.7. EQUIPMENT REQUIREMENTS AND INSTALLATION

1. Permit equipment maintenance and disassembly by use of unions or flanges to minimize disturbance to connecting piping and duct systems and without interference from building structure or other equipment.
2. Provide accessible means for lubricating equipment including permanent lubricated "lifetime" bearings.

3. Pipe drain lines to drains.
4. Line-up equipment, rectangular cleanouts and similar items with building walls wherever possible.
5. Provide equipment commissioning and preliminary balancing and confirm the proper operation of all equipment and related systems.

1.8. RESPONSIBILITY FOR TRIAL USAGE

1. Obtain written permission to start and test permanent equipment and systems prior to acceptance by Consultant.
2. Consultant may use ventilating equipment and systems for testing.
3. Protect equipment and systems' openings from dirt, dust and other foreign materials during test usage.

1.9. ELECTRICAL

1. Division 15 shall supply and install motors, controls and control wiring, supply starters, switches and relays, for all motor driven equipment under Division 15. Starters, switches and relays shall be handed over to Division 16 for installation and wiring.
2. Electrical equipment not supplied by Division 15 is listed on the drawings or elsewhere in the Specification for quality of material and workmanship.
3. Safety disconnect switches shall be supplied for each rotating equipment unless within viewing distance for motor control but max 6 m (20') supplied by Division 15 and installed by Division 16.
4. Wiring and controls for connections below 50 V, which are related to control systems are the responsibility of Division 15. Refer to Division 16 for quality of materials and workmanship.
 1. Control cables, type LVT, soft annealed copper conductors with thermoplastic insulation and colour coding. Installation in EMT conduit.
 2. Two conductors parallel with an overall thermoplastic jacket; three or more conductors twisted with an overall thermoplastic jacket.
 3. Cable to be installed in EMT conduit or to be plenum rated FT6 type.

1.10. THERMOSTATS AND SENSORS

1. All thermostats, sensors etc to be mounted at 1200mm (47") above finished floor to centre line of device. Any interference with other devices such as switches, etc to be coordinated with Consultant.

1.11. MOTORS

1. Provide motors for mechanical equipment as specified.
2. If delivery of specified motor will delay delivery of installation of any equipment, install an acceptable motor for temporary use. Final acceptance of equipment will not occur until specified motor is installed.
3. Motors under 373 W (1/2 HP) speed as indicated, continuous duty high efficiency, built in overload protection, resilient mount, single phase, 120 V unless otherwise specified or indicated.
4. Motors 373 W (1/2 HP) to 150 kW (200 HP) T frame, to or exceeding the current Ontario Hydro Motor Efficiency Levels and be listed in the current Ontario Hydro Motor Efficiency Levels Guide as tested to CSA C390M 1985 or IEEE 112B and approved under the Canadian Safety Code, speed as indicated, continuous duty, drip proof, ball bearing, maximum temperature rise 40°C (72°F), 3 phase, 208 V or 600 V unless otherwise specified or indicated.
5. Provide a suitable manual or magnetic starter for each piece of equipment supplied under this Division.
6. Provide safety disconnect switches for the above equipment.
7. Division 16 will install all starters, disconnects and line voltage control devices and perform all wiring under supervision of this Division.

1.12. PIPE HANGERS AND SUPPORTS

1. See Section 15140 – Hangers and Supports.

1.13. BELT DRIVES

1. Fit reinforced belts in sheaves matched to drive. Multiple belts to be matched set.
2. Use cast iron or steel sheaves secured to shafts with removable keys unless otherwise specified.
3. For motors up to 7.5 kW (10 HP) standard adjustable pitch drive sheaves, having plus or minus 10% range. Use mid position of range for specified r/min. Use fixed sheaves for motors 7.6 kW (10 HP) and over. Replace sheaves during balancing if required.
4. Minimum drive rating: 1.5 times nameplate rating on motor. Keep overhung loads within manufacturers design requirements on prime mover shafts.
5. Motor slide rail adjustment plates to allow for centre line adjustment.

1.14. GUARDS

1. Provide guards for unprotected drives.
2. Guards for belt drives:

1. Expanded metal screen welded to steel frame.
2. Minimum 1.3 mm (18 GA) galvanized sheet metal tops and bottoms.
3. 40 mm (1 1/2") dia holes on both shaft centres for insertion of tachometer.
4. Removable for servicing.
3. Provide means to permit lubrication and use of test instruments with guards in place.
4. Install belt guards to permit movement of motors for adjusting belt tension.

1.15. BUILDING PERMIT

1. Prepare permit application and apply for building permit at local Building Department. Include all costs in tender price. Consultant will provide contract documents in PDF format, contractor responsible to produce hard copies.

1.16. DRAIN VALVES

1. Locate at low points and at section isolating valves unless otherwise specified.
2. Minimum NPS 3/4 unless otherwise specified: bronze, with hose end male thread and complete with cap and chain.

1.17. PENETRATIONS

1. Where pipes pass through fire rated walls, floors or partitions, maintain fire rating of assembly in compliance with OBC. Submit shop drawings and details on all products.
2. Provide pipe sleeves at penetrations where pipes pass through masonry or concrete, or where protection is required from galvanic action or physical abrasion.
 1. Coat exposed exterior surfaces of ferrous sleeves with heavy application of zinc-rich paint.
 2. Where sleeves pass through masonry or concrete: backfill space around sleeve with masonry or concrete.
 3. Where sleeves pass through walls or floors: caulk space between insulation and sleeve or between pipe and sleeve with waterproof fire retardant non-hardening mastic.
 4. In foundation walls and below grade floors: pipe sleeve to be 1.25x pipe outside diameter or minimum 50mm. Fill space between pipe and sleeve with soft foam insulation.
3. Ensure no contact between copper tube or pipe and ferrous material or sleeve.
4. Continue insulation through penetrations where pipe is required to be insulated.

5. Temporarily plug all openings during construction.

1.18. SLEEVES

1. Size:
 1. Provide 5 mm (1/4") clearance between sleeve and pipe or between sleeve and insulation.
 2. Where piping passes below footings, provide min clearance of 50 mm (2") between sleeve and pipe. Fill void with elastic, water proof material. Backfill up to underside of footing with concrete of same strength as footing.
2. Provide sleeves of minimum 1.0 mm (20 GA) galvanized sheet steel with lock seam joints or use PVC pipe in non rated walls.
3. Use cast iron or steel pipe sleeves with annular fin continuously welded at mid-point through foundation walls.

1.19. ESCUTCHEONS AND PLATES

1. Provide on pipes passing through finished walls, partitions, floors and ceilings.
2. Use split type chrome plated brass, with set screws for ceiling or wall mounting.
3. Inside diameter shall fit around finished pipe. Outside diameter shall cover opening or sleeve.
4. Where sleeve extends above finished floor, escutcheons or plates shall clear sleeve extension.
5. Secure to pipe or finished surface but not insulation.

1.20. TESTS

1. Provide the following supplementary requirements to tests specified:
 1. Give 48 h notice of date when tests will be made.
 2. Do not insulate or conceal work until tested and approved.
 3. Conduct tests in presence of Consultant.
 4. Bear costs including retesting and make good.
 5. Pipe pressure:
 1. Hydraulically test water supply systems at 1-1/2 times system operating pressure or minimum 1050 kPa (150 psig).

2. Maintain test pressures without loss of 4 h unless otherwise specified.
3. Record pressure test results, indicating:
 1. Portion of piping tested.
 2. Test pressure.
 3. Test duration.
 4. Results/Comments.
 5. Type of pipe.
 6. Type of system.
 7. Size of pipe.
4. Submit results to Consultant.

1.21. PAINTING

1. Apply at least one coat of corrosion resistant primer paint to supports, and equipment fabricated from ferrous metals.
2. Restore to new condition, finishes which have been damaged too extensively to be merely primed and touched up.

1.22. SPECIAL TOOLS

1. Provide one set of special tools required to service equipment as recommended by manufacturers.

1.23. ACCESS DOORS

1. Supply access doors to concealed mechanical equipment for operating, inspecting, adjusting and servicing.
2. Flush mounted 600 mm x 600 mm for body entry and 300 mm x 300 mm for hand entry unless otherwise noted. Doors to open 180°, have rounded safety corners, concealed hinges, screwdriver latches and anchor straps.
3. Material:
 1. Special areas such as tiled or marble surfaces: use stainless steel with brushed satin or polished finish as directed by Consultant.
 2. Remaining areas: use prime coated steel.
4. Installation:

1. Locate so that concealed items are accessible.
2. Locate so that hand or body entry (as applicable) is achieved.
3. Installation is specified in applicable sections.
5. Acceptable Material: Nailor 0900 or approved equal.

1.24. DIELECTRIC COUPLINGS

1. Provide wherever pipes of dissimilar metals are joined.
2. Provide felt or rubber gaskets to prevent dissimilar metal contact.

1.25. CUTTING AND PATCHING

1. All cutting and patching shall be by Division 15. Coordinate with other trades. Notify Structural Engineer before cutting any structural members and obtain written permission.

1.26. CONCRETE WORK

1. Provide 100mm concrete housekeeping pads for all floor mounted equipment, including: expansion tanks, boilers, etc.

1.27. EXISTING SYSTEMS

1. Before submitting tender price verify on job site location of all accessible existing systems affecting execution of this contract. Difficulties arising during construction will not be considered as grounds for additional payment.
2. Where work involves breaking into or connecting to existing systems, carry out work at times directed by governing authorities, with minimum of disturbance to pedestrian traffic.
3. Submit schedule to and obtain approval from Consultant for any shut down or closure of active service or facility. Adhere to approved schedule and provide notice to affected parties.
4. Where unknown services are encountered, immediately advise Consultant and confirm findings in writing.

1.28. INSTRUCTIONS TO OWNERS

1. Provide certified personnel to instruct Owner of operation mechanical equipment. Provide maintenance specialist personnel to instruct on maintenance and adjustment of mechanical equipment and any changes or modification equipment must be under terms of guarantee.
2. Training plans to be submitted prior to the execution of the training. At a minimum, training plans to include the list of systems and equipment which are to be trained on. Instructor's name and qualifications and allotted time for training. Training plans to be reviewed and

approved by Owner and Consultant prior to commencement of training.

3. Provide instruction during regular work hours prior to acceptance and turn over to Owner's staff for regular operation.
4. Use operation and maintenance data manual for instruction purposes. On completion of instruction, turn three manuals over to the Owner.
5. Operation and maintenance manual to be approved by and final copies deposited with Consultant before final inspection.

1.29. OPERATION & MAINTENANCE MANUALS

1. Provide one (1) paper copy and one "PDF" format on USB stick of Mechanical Operation and Maintenance Manuals complete with As-built Drawings, in accordance to the following and Section 01300 - Submittals.
2. Mechanical Operation and Maintenance Manuals to be delivered to the Engineer's office in accordance with Section 01300 - Submittals.
3. Manuals to be bound in hard cover neatly labeled: "OPERATING AND MAINTENANCE INSTRUCTIONS".
4. The Operation and Maintenance Manuals shall be divided into sections with neatly labeled and tabbed dividers between each section. The sections to be included in the manual are:
 1. Section I – General
 2. Section II – Piping and Pump Systems
 3. Section III – Heating, Air Conditioning and Ventilation
 4. Section IV – Automatic Controls
 5. Section V – Sprinkler System
 6. Section VI – Air and Hydronic Balancing Report
5. The following information shall be contained within the sections:
 1. SECTION I: A list giving name, address and telephone number of the Consultant, Engineers, Construction Manager, Mechanical Trade and Controls Trade. Written guarantees for the Mechanical Systems. A copy of the Valve directory giving number, valve location, normal valve position, and purpose of valve. A framed copy of valve directory to be hung in Mechanical Room. Equipment lists and certificates shall be provided. Certificates shall be signed and sealed by the appropriate suppliers. All major equipment including but not limited to boilers, cooling towers, chillers, air handling units, isolators, silencers, pumps and humidifiers are to be inspected by the manufacturer to ensure the equipment has been installed in accordance with their recommendations.
 2. SECTION II, III and IV: A copy of all pressure tests and operational tests for

pumping system. A copy of Gas Operational Tests for gas fired equipment. A list giving name, address and telephone number of all suppliers. A copy of all approved Shop Drawings. Copies of warranties.

3. SECTION IV: Complete Control Diagrams, Wiring Diagrams and description of Control system and the functioning of the system. A copy of all shop drawings and all calibration certificates. Shop drawings shall be the updated record drawings.
4. SECTION V: A copy of all shop drawings. Copies of all warranties. Maintenance information.
5. SECTION VI: Provide complete air balance report including pump and fan curves, measured values and floor plans showing location of all traverse readings and grille measurements. Provide copies of all pressure tests completed on the systems.
6. MAINTENANCE MATRIX
 1. A maintenance matrix is to be provided in the Operation and Maintenance Manuals. The matrix shall indicate each piece of equipment and the required maintenance tasks and the frequency at which they are to be carried out.

1.30. OWNER OCCUPANCY SCHEDULE

1. The existing building will remain occupied during normal occupancy hours.
2. Provide temporary protection for all finishes, appliances or equipment in the existing building.
3. Protect and maintain existing boiler room and electrical room operations during the work.

1.31. AS-BUILT DRAWINGS

1. Site records:
 1. One set to be kept on site and all changes to be recorded on daily basis. At the completion of the project, all changes shall be transferred to clean set, signed and passed to the Consultant. Provide "PDF" format of As-Built Drawings on USB stick with Maintenance Manuals at completion of project.
 2. Make these drawings available for reference purposes and to inspection at all times.
2. Submit 2 copies of as-built marked up prints with final TAB report.
3. As-built drawings must be delivered before system acceptance.

1.32. BUILDING SERVICE CONNECTIONS

1. Make arrangements with all Utilities for building service connections and include all costs in tender price.

1.33. TRAINING

1. Provide minimum of three 4 hour training sessions on systems.

END OF SECTION 15010

PART 1 - GENERAL

1.1. GENERAL

1. Division 1, General Requirements is part of this Section and shall apply as if repeated here.

1.2. SHOP DRAWINGS AND PRODUCT DATA

1. Submit shop drawings and product data in accordance with Section 01300 - Submittals.
2. Indicate on manufacturer's catalogue literature the following:
 1. Thermometers.
 2. Pressure gauges.
 3. Stop cocks.
 4. Wells.

1.3. MAINTENANCE DATA

1. Provide maintenance data for incorporation into manual specified.

PART 2- PRODUCTS

2.1. GENERAL

1. Thermometers and pressure gauges to operate at mid point of scale or range.

2.2. DIRECT READING THERMOMETERS

1. Industrial, variable angle type, liquid in glass, cast aluminum case, lens front, 225 mm (9") scale length, dual °F and °C range. Stem lengths to be 50% of pipe i.d. Thermometers to meet: CAN/CGSB 14.4, ASME B40.4.

2.3. REMOTE READING THERMOMETERS

1. 100 mm diameter activated dial type, accuracy within one scale division, brass movement, stainless steel capillary, stainless steel spiral armour, stainless steel bulb and polished brass or stainless steel case for wall mounting. Capillary to have an extra length of at least 5 ft. Thermometers to meet: CAN/CGSB 14.4, ASME B40.

2.4. THERMOMETER WELLS

1. Copper pipe: copper or bronze.
2. Steel pipe: brass or stainless steel.
3. Provide extension necks where insulation is present.
4. Acceptable Product: WIKA TI.901; Winters TIM.

2.5. PRESSURE GAUGES

1. 112 mm, dial type, grade A, 1% accuracy full scale unless otherwise specified. Wetted parts to be of phosphor bronze bourdon tube. Dual scale PSI/Kpa.
2. Acceptable Material: WIKA 213.53.
3. Provide liquid fill on all pump systems
4. Provide siphons for steam service
5. Provide bronze stop cocks for isolation
6. Provide diaphragm seals for corrosive services.

PART 3- EXECUTION

3.1. GENERAL

1. Install so they can be easily read from floor or platform. If this cannot be accomplished, install remote reading units.
2. Install engraved lamicoid nameplates as specified in Section 15190 - Identification, identifying medium.
3. Install between equipment and first fitting or valve.

3.2. THERMOMETERS

1. Install in wells on all piping. Provide heat conductive material for inside of well.
2. Install in locations as indicated and on:
 1. Common return to boilers.
 2. Outlet of every boiler.
 3. On each return and supply.

4. On every heating coil.
5. Outlets of heat exchanger.

3. Use extensions where thermometers are installed through insulation.
4. Provide well in supply pipe header for indoor/outdoor controller temp. sensor.

3.3. PRESSURE GAUGES

1. Install in following locations:
 1. Suction and discharge of pumps.
 2. In other locations as indicated.
2. Use extensions where pressure gauges are installed through insulation.

END OF SECTION 15130

PART 1 - GENERAL

1.1. GENERAL

1. Division 1, General Requirements is part of this Section and shall apply as if repeated here.

1.2. REFERENCES

1. ASME B31.1-2012, (SI), Power Piping, (SI Edition).
2. MSS-SP-58-2009, Pipe Hangers and Supports - Materials, Design and Manufacture.

1.3. SHOP DRAWINGS AND PRODUCT DATA

1. Submit shop drawings and product data in accordance with Section 01300 - Submittals.
2. Indicate on manufacturer's catalogue literature the following:
 1. Upper attachment.
 2. Middle attachment.
 3. Pipe attachment.
 4. Riser clamps.
 5. Shields and saddles.
 6. Sway braces.

1.4. MAINTENANCE DATA

1. Provide maintenance data for incorporation into manual specified in Section 01300 - Submittals.

PART 2- PRODUCTS

2.1. GENERAL

1. Fabricate hangers, supports and sway braces in accordance with ANSI B31.1 and MSS-SP-58.
2. Support from structural members. Where structural bearing does not exist or inserts are not in suitable locations, provide supplementary structural steel members.

2.2. UPPER ATTACHMENTS

1. Concrete:
 1. Anchors for existing concrete roof structure, heavy duty anchors Hilti HSL.
2. Steel beam (bottom flange):
 1. Cold piping NPS 2 and under: malleable iron C clamp to MSS-SP-58, type 19. ULC listed.
 2. Cold piping NPS 2-1/2 and larger and all hot piping: malleable iron beam clamp to MSS-SP-58, type 28 or 29. ULC listed.
3. Steel beam (top):
 1. Cold piping NPS 2 and under: malleable iron "top of beam" C clamp to MSS-SP-58, type 19. ULC listed.
 2. Cold piping NPS 2-1/2 and larger and all hot piping: steel jaw, hook rod with nut, spring washer and plain washer, to MSS-SP-58, type 25. ULC listed.
4. Steel joist:
 1. Cold piping NPS 2 and under: steel washer plate with double locking nuts.
 2. Cold piping NPS 2-1/2 and larger and all hot piping: steel washer plates with double locking nut, carbon steel clevis and malleable iron socket.
5. Steel channel or angle (bottom):
 1. Cold piping NPS 2 and under; malleable iron C clamp to MSS-SP-58, type 23. ULC listed.
 2. Cold piping NPS 2-1/2 and larger and all hot piping; universal channel clamp. ULC listed.
6. Wood trusses and joists.
 1. Cold piping NPS 2 and under. Secure angle iron 32 x 32 x 3 mm (1 1/2" x 1 1/2" x 3/16") on top of joist or bottom chord trusses. Space min. 2 joints. Use rod hanger with locking nut and clevis hanger.
 2. Cold piping NPS 2 1/2 and larger. Secure angle iron 50 x 50 x 4 mm on top of joists or bottom chord of trusses. Span min. 4 members. Use rod hangers with locking nut and clevis hanger.

2.3. MIDDLE ATTACHMENT (ROD)

1. Carbon steel threaded rod black finish, galvanized in mechanical rooms.

2.4. PIPE ATTACHMENT

1. Cold piping, steel or cast iron: hot piping steel, with less than 25 mm, 1" horizontal movement; hot piping, steel, with more than 300 mm, 12" middle attachment rod length: adjustable clevis to MSS-SP-58, type 1. ULC listed.
2. Cold copper piping; hot copper piping with less than 25 mm, 1" horizontal movement; hot copper piping with more than 300 mm, 12" middle attachment rod length: adjustable clevis to MSS-SP-58, type 1. Copper plated.
3. Suspended hot piping, steel and copper, with horizontal movement in excess of 25 mm, 1"; hot steel piping with middle attachment rod 300 mm, 12" or less; pipe roller to MSS-SP-58, type 43.
4. Bottom supported hot piping, steel and copper: pipe roller stand to MSS-SP-58, type 45.

2.5. RISER CLAMPS

1. Steel or cast iron pipe: black carbon steel to MSS-SP-58, type 42. ULC listed.
2. Copper pipe: carbon steel copper finished to MSS-SP-58, type 42.

2.6. SADDLES AND SHIELDS

1. Hot and Cold piping NPS 1-1/4 and over: protection shield with high density insulation under shield with uninterrupted vapour barrier.

PART 3- EXECUTION

3.1. HANGER SPACING

1. Spacing and middle attachment rod diameter as specified in paragraphs below or as in table below, whichever is more stringent.
 1. Plumbing piping: most stringent requirements of Ontario Building Code, or authority having jurisdiction.
 2. Fire protection: to applicable fire code.
 3. Gas piping: up to NPS 1/2: every 6', 1.8 m
 4. Copper piping: up to NPS 1/2: every 5' 1.5 m
 5. Flexible joint roll groove pipe: in accordance with table below, but not less than one hanger at joints.
 6. Within 12" of each horizontal elbow.

Pipe Size (Nominal)	Rod Diameter	Maximum Steel	Spacing Cooper
NPS 1/2	10 mm 3/8"	1.8m 6'	5' 1.5m
NPS 3/4, 1	10 mm 3/8"	2.1m 7'	6' 1.8m
NPS 1-1/4	10 mm 3/8"	2.1m 7'	8' 2.4m
NPS 1-1/2	10 mm 3/8"	2.7m 9'	8' 2.4m
NPS 2	10 mm 3/8"	3.0m 10'	9' 2.7m
NPS 2-1/2	10 mm 3/8"	3.0m 10'	10' 3.0m
NPS 3 to 4	10 mm 3/8"	4.6m 15'	12' 3.6m
NPS 6	19 mm 3/4"	5.1 m 17'	--

3.2. HANGER INSTALLATION

1. Offset hanger so that rod is vertical in operating position.
2. Adjust hangers to equalize load.
3. Loads suspended from steel structure to be reviewed and analyzed with structural engineer/general contractor.

END OF SECTION 15140

PART 1- GENERAL

1.1. GENERAL

1. Division 1, General Requirements is part of this Section and shall apply as if repeated here.

1.2. REFERENCES

1. CGSB 1-GP-60M, Enamel, Interior, Gloss, Alkyd Type.
2. CGSB 24-GP-3a Identification and Classification of Piping Systems.

1.3. SAMPLES

1. Submit samples in accordance with Section 01300 - Submittals.
2. Submit samples and lists of proposed wording for approval before engraving.

PART 2- PRODUCTS

2.1. MANUFACTURERS NAMEPLATES

1. Provide metal nameplate on each piece of equipment, mechanically fastened complete with raised or recessed letters.
2. Indicate size, equipment model, manufacturer's name, serial number, voltage, cycle, phase and power of motors.

2.2. SYSTEM NAMEPLATES

1. Colour:
 1. Hazardous: red letters, white background.
 2. Elsewhere: black letters, white background (except where required otherwise by applicable codes).
2. Construction:
 1. 3 mm thick, laminated plastic or white anodized aluminum, matte finish, square corners, letters accurately aligned and machine engraved into core.
3. Sizes:

1. Conform to following table:

Size #	Dimensions		No. of Lines	Letter Height	
	(mm)	(in)		(mm)	(in)
1	10 x 50	3/8 x 2	1	3	1/8
2	13 x 75	1/2 x 3	1	5	1/4
3	13 x 75	1/2 x 3	2	3	1/8
4	20 x 100	3/4 x 4	1	8	3/8
5	20 x 200	3/4 x 8	1	8	3/8
6	20 x 100	3/4 x 4	2	5	1/4
7	25 x 125	1 x 5	1	12	1/2
8	25 x 125	1 x 5	2	8	3/8
9	35 x 200	1-1/4 x 8	1	20	3/4

2. Use average of 25 letters/numbers (maximum) per nameplate.

3. Use size #6 for terminal cabinets and control panels.

4. Use size #9 for equipment in mechanical rooms.

5. Facilities Inspection Program (FIP) identification:

1. General: use system of Main Identifier, Source Identifier, Destination Identifier.

2. Equipment and Mechanical Rooms: Main Identifier: size #9; Source and Destination Identifiers: size #5.

3. Elsewhere: Sizes as appropriate.

2.3. PIPING

1. General

1. To CGSB 24-GP-3a.

2. Identify medium by lettered legend, classification by primary and secondary colours, direction of flow by arrows.

2. Sizes:

1. Legend: block capitals to following table:

Outside Dia. of Pipe or Insulation		Size of Letters	
mm	in	mm	in
30	1-1/4	13	1/2
50	2	19	3/4
150	6	32	1-1/4
250	7	63	2-1/2
Over 250	8	88	3

2. Primary colour bands:
 1. At valves and fittings: 460 mm, 18" long.
 2. Elsewhere: 1.8 m, 42" long.
 3. Secondary colour bands: 50 mm, 2" wide, 75 mm, 3" in from one end of primary colour band.
3. Arrows:
 1. Outside diameter of pipe/insulation 75 mm and greater: 150 mm, 6" long x 50 mm, 2" high.
 2. Outside diameter of pipe/insulation less than 75 mm, 3": 100 mm, 4" long x 50 mm, 2" high.
 3. Use double headed arrows where flow is reversible.
3. Material:
 1. Paint: to CGSB 1-GP-60M.
 2. Legend markers, arrow colour bands: plastic coated cloth material with protective overcoating and waterproof contact adhesive undercoating, suitable for 100% RH and continuous operating temperature of 150°C (300°F). Apply to prepared surfaces. Wrap tape around pipe or pipe covering with ends overlapping one (1) pipe diameter.
 3. Waterproof and heat resistant plastic marker tags: for pipes and tubing 3/4" nominal and smaller.
 4. Acceptable material: Brady
4. Colours:
 1. Where not covered by table below, submit legend, primary and secondary classification colours to Consultant for approval.
5. Table:
 1. Pipe and valve identification.

<u>Pipe Marker Legend</u>	<u>Valve Tag Legend</u>	<u>Primary Colour</u>	<u>Secondary Colour</u>
Hot Water Htg Supply	H.W.H.S	Green	None
Hot Water Htg Return	H.W.H.R.	Green	None
Glycol Heating Supply	G.H.S.	Green	None

Glycol Heating			
Return	G.H.R.	Green	None
Gas Line	Gas	Green	None
Cold Water	C.W.	Green	None
Hot Water	H.W.	Green	None
Recirc. Hot Water	R.H.W.	Green	None

2. Legend and arrows:
 1. Black or white to contrast with primary colour.
 2. Fire protection: white on red background.
3. Fire protection system:
 1. Exposed piping identify only.
4. Natural gas:
 1. Paint entire system.
5. Low voltage control wiring installed by Division 15.

2.4. DUCTWORK

1. 2" high black stencilled letters and directional flow arrows 6" long x 2" high.

2.5. VALVES AND CONTROLLERS

1. Brass tags with 1/2" stamped code lettering and numbers filled with black paint.
2. Furnish Consultant with six identification flow diagrams of approved size for each system. Include valve tag schedule, designating number, service, function and location of each tagged item and normal operating position of valves.

2.6. CONTROLS IDENTIFICATION

1. Identify all systems, equipment, components, controls and sensors.
2. Inscription to identify function and fail-safe position.

PART 3- EXECUTION

3.1. GENERAL

1. Do identification work in accordance with CGSB 24-GP-3a except where specified otherwise.
2. Provide ULC and/or CSA registration plates, as required by respective agency.
3. Identify systems and equipment to conform to PWC, FIP.

3.2. LOCATION OF NAMEPLATES

1. In conspicuous location to facilitate easy reading from operating floor and to properly identify equipment and/or system.
2. Provide stand-offs for nameplates on hot surfaces and insulated surfaces.
3. Do not insulate or paint over plates.

3.3. PIPING

1. Locations:
 1. On long straight runs in open areas in boiler rooms, mechanical room, and tunnel so that at least one is clearly visible from any one viewpoint in operating areas or walking aisles and not at more than 15 m, 50' intervals.
 2. Adjacent to all changes in direction.
 3. At least once in each small room through which piping passes.
 4. On both sides of visual obstruction or where run is difficult to follow.
 5. On both sides of any separation such as walls, floors and partitions.
 6. Where piping is concealed in pipe chase, ceiling space, or other confined space, at entry and leaving points and adjacent to each access opening.
 7. At beginning and end points of each run and at each piece of equipment in run.
 8. At point immediately upstream of major manually operated or automatically controlled valves. Where this is not possible, place identification as close to valve as possible, preferably on upstream side.
 9. Legend to be easily and accurately readable from usual operating areas and all readily accessible points.
 10. Plane of legend to be approximately at right angles to most convenient line of sight with consideration of operating positions, lighting conditions, reduced visibility of colour or legends caused by dust and dirt and risk of physical damage.

3.4. DUCTWORK

1. Stencil over final finish only.
2. Locations of ductwork identification:
 1. On long straight runs in open areas in boiler rooms, equipment rooms, so that at least one is clearly visible from any one viewpoint in operating areas or walking isles and not at more than 15 m, 50' intervals.
 2. Adjacent to all changes in direction.
 3. At least once in each small room through which ductwork passes.
 4. On both sides of visual obstruction or where run is difficult to follow.
 5. On both sides of any separation such as walls, floors and partitions.
 6. Where ductwork is concealed in duct chase, or other confined space, at entry and leaving points and adjacent to each access opening.
 7. At beginning and end points of each run and at each piece of equipment in run.
 8. At point immediately upstream of major manually operated or automatically controlled dampers. Where this is not possible, place identification as close to damper as possible, preferably on upstream side.
 9. Legend to be easily and accurately readable from usual operating areas and all readily accessible points.
 10. Plane of legend to be approximately at right angles to most convenient line of sight with consideration of operating positions, lighting conditions, reduced visibility of colour or legends caused by dust and dirt and risk of physical damage.
 11. Beside each access door.

3.5. VALVES AND CONTROLLERS

1. Secure tags with non-ferrous chains or closed "S" hooks for valves and operating controllers except at plumbing fixtures and radiation.
2. Install one copy of flow diagram and valve schedule mounted in frame with non-glare glass where directed by Consultant. Provide one copy in each operating and maintenance instruction manual.
3. Consecutively number valves system.

END OF SECTION 15190

PART 1- GENERAL

1.1. GENERAL

1. Division 1, General Requirements is part of this Section and shall apply as if repeated here.

1.2. REFERENCES

1. Do thermal insulation in accordance with ACNBC, ASTM E96-66(1972) and ASTM C411-61 (1975).
2. Fire hazard rating:
 1. Meet NFPA 90A-2002, NFPA 225-1984 and CAN4-S102-M83 for all components of insulation system.
3. LEED Canada for New Construction and Major Renovations 2009.

1.3. DEFINITIONS

1. "CONCEALED" - insulated mechanical services in chases, furred spaces, pipe shafts or hung ceilings.
2. "EXPOSED" - will mean "not concealed" as defined herein.

PART 2- PRODUCTS

2.1. FORMED FIBROUS GLASS TO 200°C

1. Application: insulation system for piping, valves, heat exchangers, headers, fittings, etc. maximum temperature 200°C. On domestic hot water and recirculating piping, fittings and all hydronic heating hot water and glycol systems.
2. Materials:
 1. CGSB 51-GP-9M, rigid mineral fibre sleeving for piping, including foilcraft laminate packet with open mesh fibre scrim reinforcing.
 2. Acceptable materials: Knauff; Fibreglass Rigid-Wrap pipe insulation.
3. Thickness:
 1. Domestic hot water and recirculating lines – located in conditioned spaces:

Line Size Nominal	Thickness Nominal
Up to NPS 1 1/4"	25 mm (1")

NPS 1 1/2" and larger	40 mm (1 1/2")
Run-outs to fixtures	
For max. of 2.4 m (8')	25 mm (1")

2. Hydronic hot water and glycol heating media temperature up to 200°F/93°C:

Line Size Nominal	Thickness Nominal
Run-outs Up to	
3.7 m (12')	38 mm (1 1/2")
NPS 3/4" to 1 1/4"	38 mm (1 1/2")
NPS 1 1/2" to 8"	50 mm (2")

3. Steam and condensate piping systems:

Line Size Nominal	Thickness Nominal
Run-out up to 1"	63 mm (2 1/2")
NPS 1" to 4"	63 mm (2 1/2")
NPS 4" to 8"	76 mm (3")

2.2. FORMED FIBROUS GLASS WITH V.B. -14 TO 37°C

1. Application: insulation system for piping, valves, heat exchangers, headers, fittings, etc., for temperature range - 14 to 37°C. On domestic cold water, rain water leaders, above grade storm and condensate lines.

Media Temperature 41 to 56°F / 5 to 13°C

Line Size Nominal	Thickness Nominal
Up to NPS 1 1/4"	13 mm (1/2")
NPS 1 1/2" and over	25 mm (1")

2. Materials:

1. CGSB 51-GP-9M, rigid mineral fibre sleeving for piping, and CGBS 51-GP-52M vapour barrier jacket. Complete with factory applied foil laminate, reinforced with open mesh fibre scrim.

3. Thickness – Media temperature <41°F/<5°C:

Line Size Nominal	Thickness Nominal
Up to NPS 3/4"	13 mm (1/2")
Up to NPS 1" - 6"	25 mm (1")
NPS 8" and larger	38 mm (1 1/2")

2.3. FLEXIBLE ELASTOMERIC CLOSED CELL FOAM TO 82°C

1. Application – insulation of refrigeration lines, oil cooler piping, purge lines, evaporator heads, and other parts subject to sweating.

2. Material:

1. ASTM C534, sheet self-adhering, roll type, elastomeric closed cell foam, thermal performance 0.04 W/M/C @ 24°C.
3. Acceptable Material:
 1. Armstrong – AP Armaflex self-adhering sheet insulation; Rubatex
 2. Insulation Thickness – 20 mm

2.4. FASTENINGS

1. Self-adhesive tape and 100% coverage lagging adhesives.
 1. Self-adhesive tape rated under 25 for flame spread and under 50 for smoke development.
2. For vapour barrier:
 1. Quick-setting adhesive for joints and lamps sealing of vapour barriers. Flame spread 10 smoke development 0.

2.5. JACKETS

1. Fire retardant PVC jackets:
 1. Apply in all exposed areas (mechanical, boiler, storage rooms, classrooms, etc.) or other areas as noted on drawings.
 2. One-piece moulded type and sheet with pre-formed shapes at elbows, tees, valves, end-caps, reducers etc. as required.
 3. Fastening: Use solvent weld adhesive compatible with insulation, tacks, and/or vinyl tape of matching colour to seal laps and joints.
 4. Indoor: flame/smoke rating of 25/50 or less.
 5. Outdoor: UV rated material at least 0.5 mm thick.
2. Canvas:
 1. Compact, firm, ULC listed, fire rated, heavy plain weave cotton fabric at 220g/m² (0.83 oz/sq. ft.)
 2. On concealed valves and fittings use ULC listed, fire rated, plain weave cotton fabric at 120 g/m² (0.38 oz/sq. ft.)
3. Aluminum Outer Jacket:
 1. Fabricated weather resistant coating, gauge as manufacturer's recommendation.

2. Apply to piping exposed to weather.

PART 3- EXECUTION

3.1. APPLICATION

1. Apply insulation after required tests have been completed and approved by Consultant. Insulation and surfaces shall be clean and dry when installed and during application of any finish. Apply insulation materials, accessories and finishes in accordance with manufacturer's recommendations and as specified herein.
2. On piping with insulation and vapour barrier, install high density calcium silicate block under hanger shield and metal saddle. Maintain integrity of vapour barrier over full length of pipe without interruption at sleeves, fittings and supports.

3.2. INSTALLATION

1. Install in accordance with ANSI/NFPA 90A and ANSI/NFPA 90B.
2. Perform insulation work using qualified insulation applicators, in accordance with latest trade application methods and to the Consultant's approval.
3. Work to begin only when building is enclosed preventing insulation from getting wet due to elements such as rain, snow, construction, etc. All damaged or wet insulation to be replaced.
4. All piping (Section 15260) and ductwork (Section 15270) insulation to be continuous except at fire barriers.
5. Preformed: sectional up to NPS 12, sectional or curved segmented above NPS 12.
6. Multi-layered: staggered butt joint construction.
7. Vertical pipe over NPS 3: insulation supports welded or bolted to pipe directly above lowest pipe fitting. Thereafter, locate on 3 m, 15' centres.
8. Expansion joints in insulation: terminate single layer and each layer of multiple layers in straight cut at intervals recommended by manufacturer. Leave void of 25 mm, 1" between terminations. Pack void lightly with flexible mineral insulation.
9. Seal and finish exposed ends and other terminations with insulating cement.
10. Expansion joints in piping: provide for adequate movement of expansion joint without damage to insulation or finishes.
11. Orifice plate mounting flanges, flanges and unions at equipment, expansion joints, valves, other components requiring regular maintenance.
12. Insulation is not required for:

1. Chrome plated piping, valves and fittings.

3.3. FASTENINGS

1. Secure pipe insulation by tape at each end and centre of each section, but not greater than 1 m (36") on centres.

END OF SECTION 15260

PART 1 - GENERAL

1.1. GENERAL

1. Division 1, General Requirements is part of this Section and shall apply as if repeated here.

1.2. REFERENCES

1. ASTM C177-13, Test Method for Steady-State Heat Flux Measurements and Thermal Transmission Properties by Means of the Guarded-Hot-Plate Apparatus.
2. ASTM C411-11, Test Method for Hot-Surface Performance of High-Temperature Thermal Insulation.
3. CAN/ULC-S102-10, Surface Burning Characteristics of Building Materials and Assemblies.
4. ANSI/NFPA 90A, Air Conditioning and Ventilating Systems, Installation of.
5. ANSI/NFPA 90B, Warm Air Heating and Air Conditioning Systems.
6. CGSB 51-GP-10M, Thermal Insulation, Mineral Fibre, Block or Board, for Ducting, Machinery and Boilers.
7. CGSB 51-GP-11M, Thermal Insulation, Mineral Fibre, Blanket for Piping, Ducting, Machinery and Boilers.
8. CGSB 51-GP-52Ma, Vapour Barrier Jacket and Facing Material for Pipe, Duct and Equipment Thermal Insulation.
9. CAN/CGSB-51.2, Thermal Insulation, Calcium Silicate, for Piping, Machinery and Boilers.
10. CAN/CGSB-51.12, Cement, Thermal Insulating and Finishing.

1.3. SHOP DRAWINGS

1. Submit shop drawings in accordance with Section 01300 - Submittals.
2. Submit for approval manufacturer's catalogue literature related to installation.

1.4. SAMPLES SUBMITTALS

1. Submit samples in accordance with Section 01300 – Submittals.
2. Submit for approval: complete assembly of each type of insulation system, insulation coating, and adhesive proposed. Mount sample on 12 mm plywood board. Affix typewritten label beneath sample indicating service.

1.5. DEFINITIONS

1. For purposes of this section:
 1. "CONCEALED" - insulated mechanical services and equipment in hung ceilings and non-accessible chases and furred spaces.
 2. "EXPOSED" - will mean "not concealed" as defined herein.

PART 2- PRODUCTS

2.1. GENERAL

1. Components of insulation system to have maximum flame spread rating of 25 and maximum smoke developed rating of 50 in accordance with CAN/ULC-S102.
2. Materials to be tested in accordance with ASTM C411.

2.2. E-1 MINERAL FIBER BLANKET HOT CURVED SURFACES 40 TO 510°C

1. Materials:
 1. CGSB 51-GP-11M, mineral fiber blanket. CAN/CGSB-51.65, for Heat Exchanger, Chilled Water Tanks, Reheat Coil.
 2. Thermal Conductivity "k" shall not exceed 0.040 W/m. °C at 24°C mean temperature when tested in accordance with ASTM C177.

3. Applications and thickness:

<u>Service</u>	<u>Thickness</u>
1 Hydraulic Separator	50 mm (2.0")

2.3. FASTENINGS

1. Tape: self-adhesive 100 mm wide
2. Contact adhesive: quick-setting.
3. Lap seal adhesive: quick-setting for joints and lap sealing of vapour barriers.
4. Adhesive to canvas:
 1. Washable, for cementing canvas lagging cloth to equipment insulation.
5. Steel wire: galvanized annealed at 900 mm on centre before application of cement.

2.4. JACKETS

1. Canvas:
 1. Application:
 1. Heat Exchangers, water meter assembly:
 1. Material: ULC listed, fire rated, plain weave, cotton fabric, at 220 g/m².
2. Aluminum:
 1. Application:
 1. Hot Water Storage Tanks
 2. Re-heat Coil
 1. Material: fabricated weather resistant coating, gauge as per manufacturer's recommendations.

PART 3– EXECUTION

3.1. APPLICATION

1. Apply insulation after tests have been completed and approved by Consultant.
2. Surface to be clean and dry during application of insulation and finishes.
3. If not specified herein, application to be in accordance with manufacturer's recommendations.
4. Maintain uninterrupted integrity of vapour barrier.
5. Apply high density insulation under supports and hangers.

3.2. INSTALLATION

1. Install in accordance with ANSI/NFPA 90A and ANSI/NFPA 90B.
2. Insulation supports where welding or bolting is permitted.
 1. Angle anchors: weld or bolt to equipment at lowest point of insulation. Thereafter, locate every 4.5 m vertically.
 2. Welded steel clips: at 200 mm maximum on centres, but not less than 2 rows per side.
3. Insulation:

1. Multi-layered: staggered butt joints and expansion joints in insulation, secured with wire or bands at 400 mm on centre intervals.
4. Expansion joints in insulation: leave 25 mm space in each layer at 7 m intervals. Pack space lightly with Type E01 flexible mineral insulation.
5. Insulation at bolts, studs, nuts, instrumentation: bevel to permit removal without damage to insulation or finish.
6. Fastenings: secure insulation with galvanized steel wire at 900 mm on centre before application of finishing cement.
7. Vapour barriers: adhere and seal with vapour seal adhesive.
8. Finishes:
 1. Final surface: clean, smooth, ready for painting.

END OF SECTION 15280

PART 1- GENERAL

1.1. GENERAL

1. Division 1, General Requirements is part of this Section and shall apply as if repeated here.
2. All brass, bronze fittings and valves shall be "Lead Free Design".

1.2. REFERENCE STANDARDS

1. Do the work in accordance with Ontario Building Code and local authority having jurisdiction except where specified otherwise.

1.3. SHOP DRAWINGS

1. Submit product data in accordance with Section 01300 - Submittals.
2. Indicate the following: valves.

PART 2- PRODUCTS

2.1. PIPING

1. Domestic hot, cold and recirculating tubing, within building.
 1. Above ground: copper tube, hard drawn, type L: to ASTM B88M-16.
 2. Buried: soft copper tube, type K soft, with silfoss soldered joints: to ASTM B88M-16.

2.2. FITTINGS

1. Brass or bronze flanges and flanged fittings: to ASME B16.24-2016.
2. Brass or bronze threaded fittings: to ASME B16.15-2013.
3. Cast bronze to ASME B16.18-2012 or wrought copper and bronze to ASME B16.22-2013.

2.3. JOINTS

1. Solder, tin antimony, 95:5 to ASTM B32-08 (2014) or approved type lead free.

2.4. VALVES

1. For Sizes 50mm (2") and under 1034KPA (150psig) 600 WOG,
 1. Brass Body to NSF/ANSI 61-G (Lead Free Brass) Full Port, PTFE Seats, Double "O" Ring or Teflon packing. TEA Plated Forged Brass C49300 Vented Solid Ball, Blowout Proof Stem, Lever handle.
 2. Standard of Acceptance:
 1. Kitz 859 (Solder) Kitz 858 (NPT) or approved Equal
2. NPS 2 1/2 and over, grooved ends:
 1. Epoxy Coated Cast Iron Body Grooved ends, Teflon Fused Solid Ball, Full Port Rated 200 WOG @200F Class VI shutoff, 100% Lead Free,Ansi,NSF61-8
 2. Acceptable material: American 3700V or Approved Equal
 1. Option American 3700 Flanged end connection 2" to 8" or Approved Equal

2.5. SWING CHECK VALVES

1. Check Valves- Back Flow Prevention
 1. For sizes 50mm (2") and under, 860kPa (125psig) 200WOG. Bronze body to ASTM C89530 (Lead Free Bronze) Screwed Cap C49300 (Lead Free Brass) Integral Seat, PTFE Disc.
 1. Swing " Y" Pattern
 2. Screwed Ends Kitz 822T
 3. Soldered Ends Kitz 823T
 2. For sizes 65mm (2 1/2") and over use Class 150 Stainless Steel A351 CF8M Body, Trim#10, Bolted Cover PTFE Gasket, Flanged.
 1. Swing Check Flanged Kitz 150UOAM or Approved Equal
 2. Option:
 1. Wafer Check
 2. Stainless Steel, A351 CF8M Body, Class 150, 316 Stainless steel Trim
 3. Single Flapper – Moygro W15A-666 or Approved Equal
 4. Double Door
 1. Stainless Steel A351 CF8M body, Class 150, 316 Stainless steel Trim
 5. Mueller Steam Specialty Model # 72HHHHTH, or Approved Equal.

2.6. DOMESTIC BALANCING VALVES

1. Lead free 200psi. Non-shock cold working pressure, NSF/ANSI 61 and 372 certified. NIBCO PC-1810-LF or approved equal.

PART 3- EXECUTION

3.1. INSTALLATION

1. Connect to fixtures and equipment in accordance with manufacturer's instructions unless otherwise indicated.
2. Install tubing close to building structure to minimize furring, conserve head room and space. Group exposed piping and run parallel to walls.
3. Cut square, ream and clean tubing and tube ends, clean recesses of fittings and assemble without binding.
4. Lay buried tubing in accordance with AWWA Class "B" bedding.
5. Isolate equipment, fixtures and branches with gate valves.
6. Provide necessary chemicals and equipment and disinfect system to requirements of authority having jurisdiction.
7. Coordinate with the Building Inspector to witness tests and inspect work.

PART 1 - GENERAL

1.1. GENERAL

1. Division 1, General Requirements is part of this Section and shall apply as if repeated here.

1.2. REFERENCE STANDARDS

1. Do the work in accordance with Ontario Building Code and local authority having jurisdiction except where specified otherwise.
2. LEED Canada for New Construction and Major Renovations 2009.

PART 2- PRODUCTS

2.1. COPPER TUBE AND FITTINGS

1. Above ground sanitary and vent Type DWV to: ASTM B306-13 up to 2 1/2".
 1. Fittings.
 1. Cast brass: to CSA B158.1-1976.
 2. Wrought copper: to ANSI B16.29-2012.
 2. Solder: tin-lead, 50:50, to ASTM B32-08, type 50A.

2.2. CAST IRON PIPING AND FITTINGS

1. Above ground sanitary storm and vent: to CAN3-B70-M86 3" and larger.
 1. Joints.
 1. Mechanical joints.
 1. Neoprene or butyl rubber compression gaskets with stainless steel clamps.
 2. Cast iron couplings.
 1. Complete with neoprene gaskets and stainless steel bolts and nuts.

PART 3 - EXECUTION

3.1. INSTALLATION

1. Install buried pipe on 6" bed of clean washed sand, shaped to accommodate hubs and fittings, to line and grade as indicated. Backfill with 6" of clean washed sand.
2. Install piping parallel and close to walls and ceilings to conserve headroom and space, and to grade indicated.
3. Coordinate with the Building Inspector to witness tests and inspect work.

END OF SECTION 15413

PART 1– GENERAL

1.1. GENERAL

1. Division 1, General Requirements is part of this Section and shall apply as if repeated here.

1.2. REFERENCES

1. ASME B16.5-2013, Pipe Flanges and Flanged Fittings, Steel Nickel Alloy and other Special Alloys.
2. ASME B16.18-2012, Cast Copper Alloy Solder Joint Pressure Fittings.
3. ASME B16.20-2012, Ring-Joint Gaskets and Grooves for Steel Pipe Flanges.
4. ASME B16.21-2011, Non-metallic Flat Gaskets for Pipe Flanges.
5. ASME B16.22-2013, Wrought Copper and Copper Alloy Solder-Joint Pressure Fittings.
6. ASME B18.2.1-2012, Square and Hex Bolts and Screws.
7. ASTM A47M/47M-99(2004), Specification for Ferritic Malleable Iron Castings.
8. ASTM A53/A53M-12, Specification for Pipe, Steel, Black and Hot-Dipped, Zinc Coated, Welded and Seamless.
9. ASTM B32-08, Specification for Solder Metal.
10. ASTM B75/B75M-11, Specification for Seamless Copper Tube Metric.
11. CSA B149.1-10, Natural Gas Installation Code.
12. CSA W47.1-09, Certification of Companies for Fusion Welding of Steel Structures.
13. LEED Canada for New Construction and Major Renovations 2009.

1.3. PRODUCT DATA

1. Submit product data in accordance with Section 01300 - Submittals.

1.4. MAINTENANCE DATA

1. Provide maintenance data for incorporation into manual specified in Section 01300 - Submittals.

PART 2 - PRODUCTS

2.1. PIPE

1. Steel pipe: to ASTM A120 ASTM A53, Schedule 40, seamless as follows:
 1. NPS 1/2 to 2, screwed.
 2. NPS 2 1/2 and over, plain end.
2. Copper tube: to ASTM B75M.

2.2. JOINTING MATERIAL

1. Screwed fittings: pulverized lead paste.
2. Welded fittings: to CSA W47.1.
3. Flange gaskets: to ANSI B16.21 or ANSI B16.20.
4. Soldered: to ASTM B32, tin antimony 95:5.

2.3. FITTINGS

1. Steel pipe fittings, screwed, flanged or welded:
 1. Malleable iron: screwed, banded, Class 150.
 2. Steel pipe flanges and flanged fittings: to ANSI B16.5.
 3. Steel butt-welding fittings.
 4. Unions: malleable iron, brass to iron, ground seat, to ASTM A47M.
 5. Bolts and nuts: to ANSI B18.2.1.
 6. Nipples: Schedule 40, to ASTM A53.
2. Copper pipe fittings, screwed, flanged or soldered:
 1. Cast copper fittings: to ANSI B16.18.
 2. Wrought copper fittings: to ANSI B16.22.

2.4. VALVES

1. Ball Valves - Up to 50mm (2").
 1. 1034 KPA (150psig) / 600WOG Rating.
 2. Brass and or Bronze body, Full port, TFE seats, Double O-Ring Design, or Teflon

packing, Chrome plated solid Bronze ball, 3.16 Rating, CGA/CSA Approved, Lever Handle, Threaded connection.

3. Acceptable Products:

1. Kits 58, Toyo 5044A, or approved equal.
2. Lubricated Plug Valve - 65mm (2 1/2") & Over.
 1. Class 125, flanged to ANSI B16.1, Regular pattern, Regular port, Full bore lubricated plug valves.
 2. Acceptable Products:
 1. NH Canada 205m or approved equal.

PART 3– EXECUTION

3.1. PIPING

1. Install in accordance with applicable Provincial/Territorial Codes.
2. Install in accordance with CAN1-B149.1 CAN1-B149.2.
3. Assemble piping using fittings manufactured to ANSI standards.
4. Connect to equipment in accordance with manufacturer's instruction unless otherwise indicated.
5. Slope piping down in direction of flow to low points.
6. Install drip points:
 1. At all low points in piping system.
 2. At each connection to equipment.
7. Use eccentric reducers at pipe size change installed to provide positive drainage.
8. Provide clearance for access and for maintenance.
9. Ream pipes, clean scale and dirt, inside and out.
10. Install piping to minimize pipe dismantling for equipment removal.
11. Paint all gas piping yellow unless otherwise directed. Where pipe is visible on exterior walls of building, paint to match building (colour by consultant) and provide yellow banding as per CAN/CSA B149.1.

3.2. VALVES

1. Install valves with stems upright or horizontal unless otherwise approved by Consultant.
2. Install valves at all branch take-offs to isolate each piece of equipment, and as indicated.

3.3. TESTING

1. Test system in accordance with CAN1-B149.1 CAN1-B149.2.

3.4. PURGING

1. Purge after pressure test in accordance with CAN1-B149.1 CAN1-B149.2.

END OF SECTION 15482

PART 1– GENERAL

1.1. GENERAL

1. Division 1, General Requirements is part of this Section and shall apply as if repeated here.

1.2. REFERENCES

1. ASME B16.1-2010, Cast Iron Pipe Flanges and Flanged Fittings, Class 25, 125, 250 and 800.
2. ASME B16.5-2013, Pipe Flanges and Flanged Fittings, Steel Nickel Alloy and other Special Alloys.
3. ASME B16.20-2012, Ring-Joint Gaskets and Grooves for Steel Pipe Flanges.
4. ASME B16.21-2011, Nonmetallic Flat Gaskets for Pipe Flanges.
5. ASME B18.2.1-2012, Square and Hex Bolts and Screws.
6. ASTM A47M/A47M-99 (2009), Specification for Ferritic Malleable Iron Castings.
7. ASTM A53/A53M-12, Specification for Pipe, Steel, Black and Hot-Dipped, Zinc Coated, Welded and Seamless.
8. ASTM A536-84(R2009), Specification for Ductile Iron Castings.
9. ASTM B61-08, Specification for Steam or Valve Bronze Castings.
10. ASTM B62-09, Specification for Composition Bronze or Ounce Metal Castings.
11. CSA B242-05 (R2011), Groove and Shoulder Type Mechanical Pipe Couplings.
12. CSA W47.1-09, Certification of Companies for Fusion Welding of Steel Structures.
13. MSS-SP-67-2011, Butterfly Valves.
14. MSS-SP-70-2011, Cast Iron Gate Valves, Flanged and Threaded Ends.
15. MSS-SP-71-2011, Cast Iron Swing Check Valves, Flanged and Threaded Ends.
16. MSS-SP-80-2013, Bronze Gate, Globe, Angle and Check Valves.
17. MSS-SP-85-2011, Cast Iron Globe and Angle Valves, Flanged and Threaded Ends.
18. LEED Canada for New Construction and Major Renovations 2009.

1.3. SHOP DRAWINGS

1. Submit shop drawings in accordance with Section 01300 - Submittals.
2. Indicate on manufacturer's catalogue literature the following: - valves.

1.4. MAINTENANCE DATA

1. Provide maintenance data for incorporation into manual specified in Section 01300 - Submittals.

1.5. SPARE PARTS

1. Furnish following spare parts:
 1. Valve seats: one for every ten valves, each size. Minimum one.
 2. Discs: one for every ten valves, each size. Minimum one.
 3. Stem packing: one for every ten valves, each size. Minimum one.
 4. Valve handles: two of each size.
 5. Gaskets for flanges: one for every ten flanges.
 6. Couplings (Victaulic) – one for every ten joints.

PART 2– PRODUCTS

2.1. PIPE

1. Steel pipe: to ASTM A53, Grade B.
 1. To NPS 8, Schedule 40.

2.2. PIPE JOINTS

1. NPS 2 and under: screwed fittings with teflon tape.
2. NPS 2-1/2 and over: welding fittings and flanges to CSA W47.1, rolled or cut grooved piping, fittings, couplings to CSA B242.
3. Flanges: plain, slip-on or weld neck.
4. Orifice flanges: slip-on raised face, 2100 kPa.

5. Flange gaskets: Garlock.
6. Pipe thread taper.
7. Bolts and nuts: to ANSI B18.2.1.

2.3. FITTINGS

1. Cast iron pipe flanges: Class 125 to ANSI B16.1.
2. Screwed fittings: malleable iron, Class 150.
3. Pipe flanges and flanged fittings:
 1. Cast iron, Class 125: to ANSI B16.1.
 2. Steel: to ANSI B16.5.
4. Steel butt-welding fittings.
5. Unions: malleable iron, to ASTM A47M.
6. Welded type connections to be used in boiler, mechanical rooms.
7. Rolled or cut grooved standard of acceptance: Victaulic.

2.4. GATE VALVES

1. NPS 2 and under, screwed:
 1. Rising stem: to MSS SP-80, Class 125, 860 kPa, bronze body, solid wedge disc.
 2. Acceptable Products: Jenkins 810; Crane 428; Red-White 293; NIBCO T124; Kitz 24.
2. NPS 2-1/2 and over in mechanical rooms, flanged:
 1. Rising stem: to MSS SP-70, Class 125, 860 kPa, FF flanges, cast-iron body, OS & Y bronze trim.
 1. Acceptable Products: Jenkins 454J; Crane 465-1/2; Red-White 421J; NIBCO FE617; Kitz 72.
3. NPS 2-1/2 and over other than mechanical rooms, flanged:
 1. Non-rising stem: to MSS SP-70, Class 125, 860 kPa, FF flanges, cast-iron body, bronze trim, bolted bonnet.
 2. Acceptable Products: Jenkins 452J; Crane 461; NIBCO FE619; Kitz 75; Toyo 415A.

4. Acceptable Material: Jenkins; Crane; Red-White; NIBCO.

2.5. BALL VALVES

1. NPS 2 and under:
 1. Bronze body, solid ball, screwed ends, TFE seal, bronze hard chrome plated ball, 4 MPa WOG complete with stem extensions. Kitz 59 on 1" insulation or thicker.
 2. Acceptable Material: Watts 6000, Red-White 5044A, NIBCO TFP600; Kitz 58.

2.6. GLOBE VALVES

1. NPS 2 and under, screwed:
 1. To MSS SP-80, Class 125, 860 kPa, bronze body, screwed over bonnet, renewable composition disc suitable for service.
 2. Lockshield handles: where indicated.
 3. Acceptable Products: Jenkins Fig 106B, Crane 7, Red-White 221, NIBCO T235-Y; Kitz 9.
2. NPS 2-1/2 and over, flanged:
 1. To MSS SP-85, Class 125, 860 kPa, F.F. flanges, cast iron body, bronze trim, OS&Y, bolted bonnet, bronze disc and seat ring.
 2. Acceptable Material: Red-White 400A, NIBCO FE718-B; Kitz 76.

2.7. SWING CHECK VALVES

1. NPS 2 and under, screwed:
 1. To MSS SP-80, Class 125, 860 kPa, bronze body, bronze swing disc, screw in cap, regrindable seat.
 2. Acceptable Material: Jenkins Fig. 4092, Crane 37, Red-White 236, NIBCO TE413-Y; Kitz 22.
2. NPS 2-1/2 and up, flanged:
 1. To MSS SP-71, Class 125, 860 kPa, cast iron body, FF flange, renewable seat, bronze disc, bolted cap.
 2. Acceptable Material: Jenkins Eng. 587, Crane 373, Red-White 435A, NIBCO FE918-B; Kitz 78.

2.8. SILENT CHECK VALVES

1. NPS 2 and under:
 1. To ASTM B62, Class 125, 860 kPa cast steel, wafer style, brass seat rings, brass inner valve, stainless steel spring (heavy duty spring in vertical down flow application).
 2. Acceptable Material: CPV No. 36.
2. NPS 2-1/2 and over:
 1. Class 125, 860 kPa, cast steel, wafer style, bronze trim, stainless spring (heavy duty spring in vertical down flow application).
 2. Acceptable Material: CPV No. 20B, Jenkins Fig. 778, NIBCO W920-W; Mueller.
3. NPS 2, for grooved end pipe:
 1. 300 pound design, ductile iron body, stainless steel clapper, Grade E EPDM liner, suitable for 93°C operating temperature.
 2. Standard of Acceptance:
 1. Victaulic 712.
4. NPS 2 ½ and over, for grooved end pipe:
 1. 300 pound design, ductile iron body, ductile iron or bronze disc, nickel seat, EPDM liner, suitable for 93°C operating temperature.
 2. Standard of Acceptance:
 1. Victaulic 716

2.9. BUTTERFLY VALVES

1. NPS 2 ½ to 12, for grooved end pipe:
 1. 1000 kPa Class 150, long neck design malleable or ductile iron body, EPDM Grade "E" dual seal coated disc for 93°C working temperature, lever operator to NPS 4, gear operator NPS 6 to 12.
 2. Standard of Acceptance:
 1. Victaulic Series 300
 2. Nibco GD-4765
 3. Mueller 59G

PART 3– EXECUTION

3.1. PIPING INSTALLATION

1. Connect to equipment in accordance with manufacturer's instruction unless otherwise indicated.
2. Install concealed pipes close to building structure to keep furring space to minimum. Install to conserve headroom and space. Run exposed piping parallel to walls. Group piping wherever practical.
3. Slope piping in direction of drainage and for positive venting.
4. Use eccentric reducers at pipe size change installed to provide positive drainage or positive venting.
5. Provide clearance for installation of insulation and access for maintenance of equipment, valves and fittings.
6. Ream pipes, clean scale and dirt, inside and outside, before and after assembly.
7. Assemble piping using fittings manufactured to ANSI standards.
8. Saddle type branch fittings may be used on mains if branch line is no larger than half the size of main. Hole saw or drill and ream main to maintain full inside diameter of branch line prior to welding saddle.

3.2. FLUSHING AND CLEANING

1. Drain and refill entire existing building heating system.
2. Flush after pressure test for a minimum of 8 h.
3. Fill with solution of water and non-foaming, phosphate-free detergent 3% solution by weight. Circulate for minimum of 72 h.
4. Drain and flush for 8 h. Remove strainer screen/basket and clean.
5. Refill system with clean water and circulate min 4 h.
6. Drain and flush for 8 h. Remove strainer screen/basket and clean. Re-install after obtaining Consultant's approval.
7. Wet rotor pumps supplied under this project shall not be used for the flushing procedure.

3.3. FILLING OF SYSTEM

1. Refill system with clean water or inhibited propylene glycol as applicable.

3.4. VALVES

1. Install valves with stems upright or horizontal unless approved otherwise by Consultant.
2. Install ball valves at all branch take-offs and to isolate each piece of equipment, and as indicated.
3. Install globe valves for balancing and in by-pass around control valves.
4. Provide silent check valves on discharge of pumps and in vertical pipes with downward flow and as indicated.
5. Provide swing check valves on discharge of pumps and as indicated.
6. Install chain operators as indicated for valves 2 1/2" and larger in mechanical rooms when mounted more than 8'-0" above floor.

3.5. TESTING

1. Test system in accordance with Section 15010 - Mechanical General Requirements.
2. For brine systems, retest with specified quality of brine after cleaning. Repair any leaking joints, fittings or valves.

3.6. BALANCING

1. Install flow balancing valves as indicated. Acceptable Product: Taco, Tour and Anderson.
2. Balance water and glycol systems to within +/-5% of design output.

END OF SECTION 15513

PART 1– GENERAL

1.1. GENERAL

1. Division 1, General Requirements is part of this Section and shall apply as if repeated here.

1.2. REFERENCES

1. ASME Section VIII for Unfired Pressure Vessels, 1983.
2. ASTM A47M-90, Specification for Ferritic Malleable Iron Castings.
3. ASTM A278M-85(1991), Specification for Gray Iron Castings for Pressure-Containing Parts for Temperatures up to 345°C.
4. ASTM A516/516M-90, Specification for Pressure Vessel Plates, Carbon Steel, for Moderate and Lower Temperature Service.
5. ASTM A536-84, Specification for Ductile Iron Castings.
6. ASTM B62-93, Specification for Composition Bronze or Ounce Metal Castings.
7. CSA B51-03, Boiler, Pressure Vessel, and Pressure Piping Code.
8. LEED Canada for New Construction and Major Renovations 2009.

1.3. SHOP DRAWINGS

1. Submit shop drawings in accordance with Section 01300 - Submittals.
2. Indicate on manufacturer's catalogue literature: expansion tanks air vents separators valves strainers.

1.4. MAINTENANCE DATA

1. Provide maintenance data for incorporation into manual specified in Section 01300 - Submittals.

PART 2– PRODUCTS

2.1. AUTOMATIC AIR VENT

1. Standard float vent: brass body and NPS 1/8 connection and rated at 690 kPa (100 psi) working pressure.

2. Industrial float vent: cast iron body and NPS 1/2 connection and rated at 860 kPa (125 psi) working pressure.
3. Float: solid material suitable for 115°C (240°F) working temperature.

2.2. AIR SEPARATOR IN-LINE

1. Working pressure: 860 kPa (125 psi).
2. Size: same as line.
3. Acceptable Material: Armstrong, B&G, Taco.

2.3. COMBINATION AIR SEPARATORS / STRAINERS

1. Steel, tested and stamped in accordance with Section 8D of ANSI/ASME Code, for 860 kPa (125 psi) operating pressure, with stainless steel integral strainer with 3/16" perforations, tangential inlet and outlet connections, and internal stainless steel air collector tube.

2.4. COMBINATION LOW PRESSURE RELIEF AND REDUCING VALVES

1. Adjustable pressure setting: 206 kPa (30 psi) relief, 55 to 172 kPa (8 TO 25 psi) reducing.
2. Low inlet pressure check valve.
3. Removable strainer.
4. Acceptable Material: Watts, Zurn-Wilkins.

2.5. PIPE LINE STRAINER

1. NPS 1/2 to 2: bronze body to ASTM B62, screwed connections.
2. NPS 2 1/2 to 12: cast steel body to ASTM A278, Class 30, flanged connections.
3. Sizes: as indicated.
4. Blowdown connection: NPS 1 complete with ball valve and plug.
5. Screen: stainless steel with perforated size of 1/16".
6. Working pressure: 860 kPa (125 psi).

2.6. BALANCING VALVES

1. NPS 1/2 to 2 bronze body to ASTM B62, screwed connections.

2. NPS 2 1/2 to 12 cast iron, flanged connections.
3. Sized as indicated.
4. Metering ports incorporating Nordel EPT check valves on both sides of seat.
5. Y pattern, equal for percentage globe style, designed either presetting with a balance schedule or for proportional balancing.
6. Positive shut off with no drip soft seat.
7. 1/4" NPT tapped drain port on both sides of seat.
8. Four 360° adjustment turns of the handwheel with micrometer type indicator and hidden memory.
9. Preformed insulation.
10. Acceptable Material: Tour and Anderson.

2.7. BLADDER TYPE EXPANSION TANKS

1. Cylindrical galvanized steel pressurized type with replaceable heavy duty butyl bladder suitable for 115°C operating temperature.
2. Code rated for 860 kPa test pressure with ASME stamp and certification, air precharged to 84 kPa (initial fill pressure of system).
3. Charging valve – 0.302"-32 charging valve connection (standard tire valve).
4. Saddles for horizontal installation or base mount for vertical installation.
5. Standard of Acceptance: Amtrol Extrol; Taco Tacotrol; ITT Bell & Gossett; Conbraco, Expanflex.

PART 3– EXECUTION

3.1. GENERAL

1. Install as indicated and to manufacturer's recommendations.
2. Pipe drains and blow off connections to nearest drain.
3. Maintain proper clearance to permit service and maintenance.
4. Should deviations beyond allowable clearances arise, request and follow Consultants directive.
5. Refer to manufacturer's installation drawings.

6. Check that all openings for appurtenances and equipment operating weight conform to shop drawings.

3.2. STRAINERS

1. Install in horizontal or down flow lines.
2. Ensure clearance for removal of basket.
3. Install ahead of each pump, water meter.
4. Install ahead of each automatic control valve larger than NPS 1, pressure reducing valve and as indicated.

3.3. AIR VENTS

1. Install at high points of systems.
2. Install gate valve on automatic air vent inlet. Run discharge to nearest drain or service sink.
3. Install at each heating coil, glycol coil and chilled water coil.

3.4. PRESSURE SAFETY RELIEF VALVES

1. Pipe discharge to nearest drain.

3.5. BALANCING VALVES

1. Handwheel and metering ports shall not be located on bottom of valve to prevent sediment deposits. Setting must be readable without the use of mirrors or special tools.

3.6. EXPANSION TANKS

1. Diaphragm type or closed cylindrical type.
2. Equalizer line from piping system to bottom of tank.
3. Domestic cold water line with globe valve, strainer, and line size backflow preventer with isolating valves connected to equalizer line.
4. Water make-up assembly on domestic water line on tank side of backflow preventer.
5. Code rated water safety relief valve, located in piping near bottom of tank with relief pressures set to maintain 70 kPa at highest point in system with pumps off.
6. Relief valve of minimum 20 mm size and of same model and size as relief valve used on heating convertor, if tank is connected to steam generated hot water system.

7. Relief connection on backflow preventer, on make-up assembly, and safety relief valve piped to nearest open drain.
8. Pressure gauge to show pressure in tank.

END OF SECTION 15515

PART 1– GENERAL

1.1. GENERAL

1. Division 1, General Requirements is part of this Section and shall apply as if repeated here.
2. All pumps regulated under NRCan's Energy Efficiency Regulations shall be tested, labelled using the EEV mark, and listed in NRCan's database. Submittals shall identify PEI_{CL} index.

1.2. SHOP DRAWINGS

1. Submit product data and technical information in accordance with Section 01300 - Submittals.
2. Submit manufacturer's detailed composite wiring diagrams for control systems showing factory installed wiring and equipment on packaged equipment or required for controlling devices or ancillaries, accessories and controllers.
3. Submit shop drawings of pump curves for review.
4. Indicate piping, valves and fittings shipped loose by packaged equipment supplier, showing their final locations in field assembly.

1.3. MAINTENANCE DATA

1. Provide maintenance data for incorporation into manual specified in Section 01300 - Submittals.

PART 2– PRODUCTS

2.1. IN-LINE COMMERCIAL DUTY CIRCULATING PUMPS

1. Inline Constant Speed Wet Rotor - Volute: shall be constructed with either bronze or Cast-Iron bodies. Cast Iron body circulating pumps shall have a factory applied Cataphoresis coating.
 1. Impellers: will be constructed of a high strength, glass filled polypropylene engineered composite.
 2. Shafts: shall be constructed of high quality stainless steel.
 3. Seal Assembly: not available or required
 4. Motors: shall be two speed (manually adjustable) and have a minimum of class H winding insulation as defined by UL 778. Stator thermal overload sensors

are provided as an integral part of the pump and are potential-free, normally closed contact (maximum load 250 volt/1 amp). Single phase models shall have an LED indicating power is present at the terminal strip. Additionally, three phase models shall have a warning LED indicating the circulator is running in reverse rotation.

5. Motor bearings: shall be metal impregnated carbon, self lubricated sleeve bearing type.
 6. Motor Terminal Boxes: The circulating pumps shall have a high quality cast aluminum terminal box with NPT electrical connections and a secure, gasketed cover, Class 2 protection level.
 7. Capacity and size: as indicated on pump schedule.
 8. Standard of Acceptance: Wilo, Grundfos, Armstrong, Bell & Gossett.
2. Single suction close coupled vertical in-line centrifugal pump:
1. Bronze fitted type
 2. Cast iron casing with motor mounting flange and drip rim and tapping for drain connection
 3. Alloy steel or stainless steel shaft
 4. Bronze, cast iron, or stainless steel, enclosed, dynamically balanced impeller keyed to motor shaft and secured with locking nut or screw.
 5. Cast iron radially split end suction volute with flanged suction and discharge, drain plug, vent cock and suction and discharge pressure gauge tappings.
 6. Mechanical seal with positive seal flushing system.
 7. Standard of acceptance:
 1. Grundfos
 2. Wilo

2.2. HIGH EFFICIENCY COMMERCIAL CIRCULATORS

1. Pump(s)
 1. Shall be of variable speed, high efficiency, electronically commutated motor-driven, wet-rotor circulator pump design.
 2. Pump Housing: Grey Cast Iron surface-treated with Cataphoretic coating.
 3. Impeller(s) shall be constructed of glass fiber reinforced PPS-GF40.

4. Shaft: stainless steel.
 5. Bearing: Carbon-Graphite.
 6. Capacity: as indicated on drawings.
2. Motor/Electronics
 1. Electronically Commutated Motor.
 2. Voltage and Hz: as indicated on drawings.
 3. Shall have a protection class of Enclosure 2 with Class F insulation.
3. HMI
 1. Shall have a 4.3" LED color screen.
 2. Shall allow for easy menu navigation using "GREEN BUTTON" technology.
 3. Shall have the following, selectable, control modes:
 1. Permanent, automatic performance adaptation to system requirements without set point specification
 2. Constant temperature .
 3. Constant differential temperature.
 4. Needs-based volume flow optimization of the feeder pump through connectivity and communication between multiple pumps.
 5. Constant volume.
 6. Differential pressure control.
 7. Constant differential pressure.
 8. Variable differential pressure (with the option to set the nominal duty point).
 9. Constant speed.
 10. User-defined PID control.
 4. Shall have the following display characteristics:
 1. Control mode.
 2. Setpoint.
 3. US gallons per minute.

4. Power consumption.
5. Active influences (e.g. STOP, No-flow Stop).
6. Fault; yellow screen – pump still runs.
7. Failure; red screen – pump stop.
5. Shall have the following I/O:
 1. Two configurable analogue inputs: 0–10 V, 2–10 V, 0–20 mA, 4–20 mA and commercially available PT1000;
 2. +24 V DC power supply.
 3. Two configurable digital inputs (Ext. OFF, Ext. Min, Ext. Max, heating/cooling, manual override (uncoupled from building automation, operation lock (key lock and remote operation configuration protection.
 4. Two configurable signal relays for operational and fault messages.
 5. Modbus compatible.
 6. Integrated temperature sensor.
 7. Automatic emergency operation with definable pump speed for exceptional circumstances, e.g. bus communication or sensor value malfunction.
 8. Cable break detection when using an analogue signal (in connection with 2–10 V or 4–20 mA).
 9. Pre-set date and time.
4. Functions
 1. Heat quantity measurement.
 2. Pump automatically deactivates when no flow is detected.
 3. Adjustable volume flow limiter using the Q-Limit function.
 4. Ability to save and restore configured pump settings of up to three restoration points.
 5. Fault and warning messages shown in plain text with advice on resolving the issue.
 6. Pump venting function for automatic venting of the rotor chamber.
 7. Automatic setback operation.
 8. Automatic deblocking function and integrated full motor protection.
 9. Dry-running detection.

5. Acceptable Material
 1. Grundfos, and Wilo.

PART 3– EXECUTION

3.1. INSTALLATION

1. In-line circulators: install as indicated by flow arrows. Support at flanges or near unions on outlets of unit. Install with bearing lubrication points accessible. Check rotation.
2. Ensure that pump body does not support piping or equipment. Provide stanchions or hangers for this purpose. Refer to manufacturer's installation instructions for details.
3. Pipe drain tapping to floor drain.
4. Install volute venting pet cock in accessible location.
5. Complete testing and commissioning process.

END OF SECTION 15540

PART 1– GENERAL

1.1 GENERAL

1. Division 1, General Requirements is part of this Section and shall apply as if repeated here.

1.2. REFERENCES

1. ANSI/ASME Boiler and Pressure Vessel Code, Section VII-1998 and requirements and standards.

1.3. SHOP DRAWINGS

1. Submit shop drawings in accordance with Section 01300 - Submittals.

1.4. OPERATION AND MAINTENANCE DATA

1. Provide operation and maintenance data for water treatment equipment for incorporation into manual specified in Section 01300 - Submittals.

PART 2– PRODUCTS

2.1. MANUFACTURER

1. Equipment, chemicals and service by one manufacturer.
2. Acceptable material: Specialty Chemicals of Drew Chemical Ltd.

2.2. CHEMICAL FEEDING

1. Pot feeder with isolating drain, by-pass valves and micron filter. One for each hot water and glycol system.

2.3. SUPPLY OF CHEMICALS

1. Provide one year supply of chemicals for control of scale, sludge and corrosion.

2.4. TEST EQUIPMENT

1. Provide, for each type of system specified herein, one set of basic test equipment complete with carrying case and reagents for chemicals supplied. Include required specialized or supplementary equipment.

PART 3 - EXECUTION

3.1. INSTALLATION

1. Perform HVAC water treatment in accordance with ASME Boiler Code Section VII, and requirements and standards of authorities having jurisdiction, except where specified otherwise.
2. Ensure adequate clearances to permit performance of servicing and maintenance of equipment.
3. Tests to be witnessed by the Consultant or commissioning agent.
4. Provide training, minimum of 4 hours.

3.2. WATER TREATMENT SERVICES

1. Provide water treatment monitoring and consulting services for period of one year after system start-up. Service to include:
 1. Initial water analysis and treatment recommendations including testing and adjustment of pH level.
 2. System start-up assistance.
 3. Operating staff training.
 4. Visit plant every 90 days during period of operation or as required until the system stabilizes, and advise on treatment system performance.
 5. Provide necessary recording charts and log sheets for one year operation.
 6. Provide necessary laboratory and technical assistance.
 7. Instructions and advice to operating staff to be clear and concise and in writing.

3.3. CLEANING OF SYSTEM

1. Provide copy of recommended cleaning procedures and chemicals for approval by Consultant.
2. Thoroughly flush heat exchangers and heating system piping, steam, condensate, hot water and glycol with approved cleaning chemicals designed to remove deposition from construction such as pipe dope, oils, loose mill scale and other extraneous materials. Chemicals to inhibit corrosion of various system materials and be safe to handle and use.
3. During circulation of cleaning solution, periodically examine and clean filters and screens and monitor changes in pressure drop across equipment.
4. Drain and flush systems until alkalinity of rinse water is equal to make-up water. Refill with

clean water treated to prevent scale and corrosion during system operation.

END OF SECTION 15545

PART 1 - GENERAL

1.1 RELATED SECTIONS

1. Conform to Sections of Division 1 as applicable.
2. Conform to General Mechanical Requirements Section 15010 as applicable.

1.2 RELATED SECTIONS

- .1 Concrete bases and pads (except inertia bases) for mechanical equipment: Division 3.
- .2 Painting: Section 09 91 23, Painting and Finishing.
- .3 Piping insulation: Section 15260.
- .4 Water treatment systems: Section 15545.
- .5 Balancing and adjusting: Section 15990.
- .6 Electrical wiring: Division 16.

1.3 REFERENCES

CSA B51	Boiler, Pressure Vessel and Pressure Piping Code
CSA B52	Mechanical Refrigeration Code
CAN/CSA B149.1	Natural Gas and Propane Installation Code.
ASME Unfired Pressure Vessel Code, Section VIII	
ASME Boiler and Pressure Vessel Code: Section IV	

1.4 SUBMITTALS

- .1 **Shop Drawings:** Prepare and submit shop drawings for all equipment and systems covered by this Section.
- .2 Operational and Maintenance Data
 - .1 Provide equipment literature, operating instructions, maintenance instructions, parts lists, and other pertinent data for all equipment and systems covered by this Section.

1.5 QUALITY ASSURANCE

- .1 Regulatory Requirements
 - .1 Boilers, pressure vessels and all fittings installed in pressurized system must be

constructed, tested, approved and installed in accordance with the Laws and Regulations of the Ontario Ministry of Consumer and Commercial Relations - Pressure Vessels Safety Branch.

- .2 Install natural gas piping and equipment to conform with applicable requirements of CGA B149.1, Installation Code for Natural Gas Burning Appliances and Equipment, and the Ontario Gas Utilization Code.
- .3 Install equipment or devices for discharging the products of fuel burning equipment to atmosphere in accordance with laws and regulations of the Ontario Ministry of Environment, Air Pollution Control Act.

PART 2 - PRODUCTS AND MATERIALS

2.1 PIPE, FITTINGS AND VALVES

- .1 Wherever possible, provide all valves supplied by one manufacturer.
- .2 Provide chain wheel operators and operating chain for all valves located more than (2m) (7 ft.) above floor or walkway.
- .3 Provide chain of sufficient length to extend to within (2m) (7 ft.) of operating platform or floor for free hanging chains, or to within (1.5 m) (5 ft.) of floor in locations where chain can be secured to wall or column. Provide wall hook as required for securing chain to wall or column.
- .4 Provide chain wheels complete with guide, rustproof chain and of size recommended by the valve manufacturer for proper operation of the valve.
- .5 Do not use pipe of NPS 3-1/2 and 5 for piping systems covered by this Section.

2.2 HEATING BOILERS

- .1 Approved Manufacturers
Triangle Tube
- .2 General
 - .1 Supply and install hot water heating boilers as indicated and in the arrangement shown on the Drawings.
 - .2 Sealed combustion firing package boiler: B#1, B#2 and B#3 complete with burner and necessary accessories and controls, designed and constructed to Section IV, ASME Code.
- .3 Performance:
 - .1 Ratings: in accordance with HYDI (Hydronics Institute), ABMA (American Boiler Manufacturers Association), or ANSI Z21.13-2000, testing procedures.

- .4 Boilers shall be input as indicated, 95% efficient 115/1/60 power and shall incorporate the following features:
- .5 ASME Boiler Certification – ASME “H” Stamp
- .6 Unit complies with ANSI Z21.13 and CSA 4.9.
- .7 Fully condensing – 95.1% thermal efficiency.
- .8 Full modulation capability for 18% to rated input.
- .9 Low pressure drop heat exchanger.
- .10 Approved for zero clearance to combustibles (excluding vent and boiler piping).
- .11 Automatic boiler freeze protection.
- .12 Stainless steel heat exchanger construction – 439 Grade.
- .13 Self cleaning flue ways in heat exchanger.
- .14 Low NO_x Operation.
- .15 Digital display control panel.
- .16 Complete with floor stand.
- .17 Standard equipment:
 - ASME 45 psi pressure relief valve
 - Pressure and temperature gauge
 - High limit temperature safety control
 - Outdoor temperature reset control
 - Air purging valves
 - 24 volt terminal strip
 - Jumpers for manual reset or automatic reset
 - Pressure low water cutoff feature
- .18 Stainless steel premix burner.
- .19 Reliable spark ignition.
- .20 High water content.
- .21 Swing out control panel for easy service access.
- .22 Limited 10 year warranty.
- .23 Concrete housekeeping pads will be provided under each boiler under Division 3.
- .24 Run gas rated CPVC piping for exhaust and intake for boilers. Refer to manufacturer's

instructions for installation clearances and instructions.

- .25 Arrange with the manufacturer for a factory trained technician to be present during initial boiler start-up at the site to offer technical assistance if required.
- .26 Division 16 will run power wiring to the burner control panel. Include all other power and control wiring, starters and necessary transformers to suit this supply and to suit control components.
- .27 Extended Warranty: the boilers shall be covered with two years full warranty for entire boilers and ten years limited warranty.
- .28 Boiler cascade system to come with factory pre-programmed Protonode Modbus to BACnet IP and MS/TP protocol converter.

PART 3 - EXECUTION

3.1 INSTALLATION

- .1 Install boilers and related equipment in accordance with ASME Boiler and Pressure Vessels Code Section IV, the laws and regulations of the Ontario Ministry of Consumer and Commercial Relations - Pressure Vessels Safety Branch, CSA B51, and to manufacturer's recommendations.
- .2 Connect all piping to inlets and outlets as required and recommended by boiler manufacturer.
- .3 Maintain clearances indicated or recommended by manufacturer for operation, servicing and maintenance without disrupting the operation of any other equipment.
- .4 Install boilers level where shown on Drawings.
- .5 Pipe hot water relief valves full size to nearest drain (to drain as shown).
- .6 Pipe steam relief valve through roof with drip pan elbow piped to nearest drain (to drain as shown).
- .7 Wire factory supplied cascade cables from master boiler to each slave boiler in series.
- .8 Configure factory supplied Protonode for integration with BMS. Consult with boiler manufacturers representative for technical detail on setup and ensure communication with device prior to BMS integration.
- .9 BMS to provide setpoint and enable to master boiler via BACnet communication protocol. Boiler circulators controlled via on board boiler control including minimum on/off delays and freeze protection.

3.2 COMMISSIONING

- .1 Arrange for manufacturer to certify installation, provide start-up and commissioning services including but not limited to the Protonode BACnet device, perform on-site performance tests and demonstrate operation and maintenance procedures to School

Board operating personnel.

- .2 Provide Consultant at least 24 hours notice prior to inspections, tests, and demonstrations. Submit written report of inspections and test results to Consultant. Training shall occur on a different date to start up. Include for a minimum of four (4) hours.

END OF SECTION 15555

PART 1 - TAB AGENCY

1. General:
 1. The basic testing and balancing shall be provided by Division 15 and in accordance with this Section.
 2. The independent TAB Agency employed and paid by Division 15 will be providing the final testing and balancing.
 3. Division 1, General Requirements is part of this Section and shall apply as if repeated here.
2. Quality assurance:
 1. TAB to be performed to standards of ASHRAE.
3. Co-ordination:
 1. Co-ordinate all work specified in this Section.
 2. Provide all facilities required by TAB Agency in order to carry out work of this Section.
4. Adequacy of work for TAB:
 1. TAB Agency to review contract documents before work is started and confirm in writing to Consultant adequacy of provisions for TAB and all other aspects of installation pertinent to TAB.
 2. Division 15 shall provide equipment commissioning and preliminary balancing and confirm the proper operation of all systems.
5. List of TAB Agencies:
 1. ABG Air Balance Group
(416) 283-0637
 2. Aerodynamics Inspecting Consultants Ltd.
(905) 625-4388
 3. Design Test Balance
(905) 886-6513

PART 2- GENERAL

1. TAB: means to test, adjust and balance all systems to perform in accordance with Contract Documents.
2. Follow start-up procedures as recommended by manufacturer unless otherwise specified.

3. Special start-up procedures may be specified elsewhere.
4. Notify Consultant 7 days prior to start of TAB.
5. Operate all systems to permit TAB to be performed.
6. TAB to apply to systems, equipment and related controls specified in Division 15.
7. Reference organization standards:
 1. Do TAB over entire operating range in accordance with most stringent conditions of this specification and standard of following organization.
8. Alternate season testing to be provided by TAB Contractor where applicable.
9. TAB Contractor to inspect site during construction in order to assure that all balancing devices are installed properly and in pre-selected locations.
10. Mechanical contractor to provide the TAB contractor with all related approved shop drawings and change notices.
11. Start TAB only when building is essentially completed, including:
 1. Installation of ceilings, doors, windows and other construction affecting TAB.
 2. Application of sealing, caulking and weatherstripping.
 3. All pressure, leakage and other tests specified elsewhere in Division 15 completed.
 4. All provisions for TAB are installed and operational.
12. Start-up, verification for proper, safe and normal operation of mechanical and associated electrical and control systems affecting TAB including, but not limited to, the following:
 1. Proper thermal overload protection in place for electrical equipment.
 2. Air Systems:
 1. Filters in place and in clean condition.
 2. Duct systems clean of debris.
 3. Air shafts, ceiling plenums are airtight to within specified tolerances.
 4. Correct fan rotation.
 5. Fire and volume dampers in place and open.
 6. Coil fins cleaned and combed.
 7. Access doors closed and duct end caps in place.

8. All outlets installed and connected.
13. Accuracy tolerances:
 1. Do TAB to following tolerances of design values:
 1. HVAC systems: Plus 5%; minus 5%.
 2. As original tolerances.
 3. Measurements to be accurate to within plus or minus 2% of actual values.
 2. Instrument calibration: to be in accordance with TAB referenced organization standard, but within 3 months of commencement of TAB.
14. Submittals prior to commencement of TAB:
 1. Proposed methodology and procedures for performing TAB.
 2. Proposed check lists and report forms.
 3. List of instrumentation, including details and certificates of calibration.
15. Report:
 1. Format to be in accordance with TAB referenced organization standard, but using SI units.
 2. Report to include as built full system schematics showing results of TAB.
 3. Submit, prior to formal submission of TAB reports, for checking and approval by Consultant, sample of rough TAB sheets. Include:
 1. Details of instruments used.
 2. Details of TAB procedures employed.
 3. Calculations procedures.
 4. Summaries.
 4. Submit 3 copies of TAB reports, each in "D" ring binders, complete with index tabs for verification and approval of Consultant.
16. Verification:
 1. Reported measurements shall be subject to verification by Consultant. Provide instrumentation and manpower to verify results of up to 30% of all reported measurements. Number and location of verified measurements to be at discretion of Consultant.
 2. Bear costs to repeat TAB, as required, to satisfaction of Consultant.

1. Settings: lock and permanently mark settings as required by reference standard.
2. Completion: TAB to be considered complete only when final reports are approved by Consultant.

PART 3- HYDRONIC SYSTEMS

1. General: measurements as required by referenced standards, including, but not limited to, the following:
 1. Measurements:
 1. Flow
 2. Pressure
 3. Temperature
 4. RPM
 5. Electrical power
 1. Voltage
 2. Current draw.
 2. Location of equipment measurements.
 1. Inlet and outlet of each:
 1. Boiler
 2. Pumps
 3. Fin radiation/heating elements
 4. HEX
 5. PRV's
 6. Domestic hot water heaters
 7. Humidifiers
 8. Other auxiliary equipment.
 3. Location of system measurements at:
 1. Supply and return of each primary and secondary loop of following hydronic systems:
 1. Heating water, glycol.
 2. Domestic hot water return line system.
 4. Accuracy:
 1. Plus 5%, minus 5% of design values

2. Measurements to be accurate to within plus or minus 2% of actual values
5. Reports to be done as per Section 2.8.12.

END OF SECTION 15990

PART 1 - GENERAL

1.1. GENERAL

1. Division 1, General Requirements is part of this Section and shall apply as if repeated here.
2. This Section covers items common to Sections of Division 16. This Section supplements requirements of Division 1.
3. Coordinate all requirements with general contractor.

1.2. CODES AND STANDARDS

1. In this document, all references to Code numbers shall mean "Latest Edition".
2. Do complete installation in accordance with Ontario Electrical Safety Code.
3. Do complete installation in accordance with CSA C22.1-12 except where specified otherwise.
4. Comply with all CSA and inspection Authority Bulletins in force at time of Tender.
5. Abbreviations for electrical terms: to CSA Z85-1983.
6. Where requirements of this specification exceed those of above mentioned standards, this specification shall govern.

1.3. DEFINITIONS

1. "Provide" means supply and install.
2. "Approved" means approved in writing by Consultant.
3. "Inspection Authority" means Electrical Safety Authority.
4. "Consultant" means designated qualified professional engineer acting as representative of Owner for monitoring of work.
5. "Manual" means Operations and Maintenance manual.
6. "OESC" means latest edition of Ontario Electrical Safety Code

1.4. CARE, OPERATION, START-UP AND INSTRUCTION TO OWNERS

1. Provide certified personnel to instruct Owner of operation of electrical equipment. Provide maintenance specialist personnel to instruct on maintenance and adjustment of electrical equipment and any changes or modification of equipment must be under terms of guarantee.

2. Provide instruction during regular work hours prior to acceptance and turn over to Owner's staff for regular operation.
3. Provide these services for such period, and for as many visits as necessary to put equipment in operation, and ensure that operating personnel are conversant with all aspects of its care and operation.
4. Use operation and maintenance data manual for instruction purposes. On completion of instruction, turn three manuals over to the Owner.
5. Operation and maintenance manual to be approved by and final copies deposited with Consultant before final inspection.

1.5. AS-BUILT DRAWINGS

1. Site records:
 1. One set to be kept on site and all changes to be recorded on daily basis. At the completion of the project, all changes shall be transferred to clean set, signed and passed to the Consultant.
 2. Make these drawings available for reference purposes and to inspection at all times.
2. As-built drawings must be delivered before system acceptance.

1.6. VOLTAGE RATINGS

1. Operating voltages: to CAN3-C235-83 (R2006).
2. Motors, electric heating, control and distribution devices and equipment to operate satisfactorily at 60 Hz within normal operating limits established by above standard. Equipment to operate in extreme operating conditions established in above standard without damage to equipment.

1.7. PERMITS, FEES AND INSPECTION

1. Submit to Inspection Authority necessary number of drawings and specifications for examination and approval prior to commencement of work.
2. Consultant will provide drawings and specifications required by Inspection Authority at no cost.
3. Submit Notice of Project to Ministry of Labour.
4. Pay associated fees and obtain all permits required for the performance of the work.
5. Notify Consultant of changes required by Inspection Authority prior to making changes.
6. Furnish Certificates of Acceptance from Inspection Authority on completion of work to Consultant.

1.8. MATERIALS AND EQUIPMENT

1. Provide materials and equipment in accordance with Division 1.
2. Equipment and material to be CSA certified. Where there is no alternative to supplying equipment which is not CSA certified, obtain special approval from Inspection Authority.
3. Factory assemble control panels and component assemblies.

1.9. ELECTRIC MOTORS, EQUIPMENT AND CONTROLS

1. Verify installation and co-ordination responsibilities related to motors, equipment and controls with other trades and as indicated.
2. Mechanical contractor shall supply and install all motors, controls and control wiring. Mechanical contractor shall supply all disconnect switches, starters, motor rated switches and relays, for all motor driven equipment under mechanical contract. All disconnect switches, starters, motor rated switches and relays shall be handed over to electrical contractor for installation and wiring. Both mechanical and electrical contractors to coordinate to ensure proper protection and equipment is provided and included in contract.
3. Control wiring and conduit to be installed in accordance with Section 16111 and 16122, except for connections below 50 V which are related to control systems specified in mechanical sections and as shown on mechanical drawings.
4. Electrical equipment not supplied by mechanical contractor is listed on the drawings or elsewhere in the specifications. Electrical contractor to coordinate with mechanical contractor to ensure proper protection and equipment is provided for all equipment and is included in Contract.

1.10. EQUIPMENT IDENTIFICATION

1. Identify electrical equipment with nameplates and labels as follows:
2. Nameplates:
 1. Lamacoid 3 mm (1/8") thick plastic engraving sheet, white face, black core, mechanically attached with self tapping screws. For emergency power circuits, use a red face and black core.

NAMEPLATE SIZES

Size 1	10 x 50 mm (3/8 x 2")	1 line	3 mm (1/8") high letters
Size 2	12 x 70 mm (1/2 x 3")	1 line	5 mm (1/4") high letters
Size 3	12 x 70 mm (1/2 x 3")	2 lines	3 mm (1/8") high letters
Size 4	20 x 90 mm (3/4 x 4")	1 line	8 mm (3/8") high letters
Size 5	20 x 90 mm (3/4 x 4")	2 lines	5 mm (1/4") high letters
Size 6	25 x 100 mm (1" x 4")	1 line	12 mm (1/2") high letters
Size 7	25 x 100 mm (1" x 4")	2 lines	6 mm (1/4") high letters

-
3. Labels:
 1. Embossed plastic labels with 6 mm (1/4") high letters unless specified otherwise.
 4. Wording on nameplates and labels to be approved by Consultant prior to manufacture.
 5. Allow for average of twenty-five (25) letters per nameplate and label.
 6. Identification to be English.
 7. Nameplates for terminal cabinets and junction boxes to indicate system and/or voltage characteristics.
 8. Disconnects, starters and contactors: indicate equipment being controlled and voltage.
 9. Terminal cabinets and pull boxes: indicate system and voltage.
 10. Transformers: indicate capacity, primary and secondary voltages.
 11. Coordinate names of equipment and systems with Division 15 to ensure that identical names are used.

1.11. WIRING IDENTIFICATION

1. Identify wiring with permanent indelible identifying markings, either numbered or coloured plastic tapes, on both ends of phase conductors of feeders and branch circuit wiring.
2. Maintain phase sequence and colour coding throughout.
3. Colour code: to CSA C22.1.
4. Use colour coded wires in communication cables, matched throughout system.

1.12. CONDUIT AND CABLE IDENTIFICATION

1. Colour code conduits, boxes and metallic sheathed cables.
2. Code with plastic tape or paint at points where conduit or cable enters wall, ceiling, or floor, and at 15 m intervals.
3. Colours: 25 mm (1") wide prime colour and 20 mm (3/4") wide auxiliary colour.

	PRIME	AUXILIARY
up to 250 V	yellow	
up to 600 V	yellow	green
up to 5 kV	yellow	blue
up to 15 kV	yellow	red
Telephone	green	
Other communication systems	green	blue
Fire alarm	red	

Emergency Voice Other security systems	red	blue
	red	yellow

1.13. WIRING TERMINATIONS

1. Lugs, terminals, screws used for termination of wiring to be suitable for either copper or aluminum conductors.

1.14. MANUFACTURERS AND CSA LABELS

1. Ensure that manufacturer's registration plates are properly affixed to all apparatus showing the size, name of equipment, serial number, and all information usually provided, including voltage, cycle, phase and the name and address of the manufacturer.
2. Do not paint over registration plates or approved labels. Leave openings through insulation for viewing the plates. Contractors or sub-contractors nameplate not acceptable.

1.15. WARNING SIGNS

1. As specified and to meet requirements of Inspection Authority and Consultant.

1.16. MOUNTING HEIGHTS

1. Mounting height of equipment is from finished floor to centreline of equipment unless specified or indicated otherwise.
2. If mounting height of equipment is not specified or indicated, verify before proceeding with installation.

1.17. FIELD QUALITY CONTROL

1. All electrical work to be carried out by qualified, licensed electricians or apprentices as per the conditions of the Provincial Act respecting manpower vocational training and qualification. Employees registered in a provincial apprentices program shall be permitted, under the direct supervision of a qualified licensed electrician, to perform specific tasks – the activities permitted shall be determined based on the level of training attained and the demonstration of ability to perform specific duties.
2. Conduct and pay for following tests:
 1. Power distribution system including phasing, voltage, grounding.
 2. Circuits originating from branch distribution panels.
 3. Motors and associated control equipment including sequenced operation of systems where applicable.

3. Furnish manufacturer's certificate or letter confirming the entire installation as it pertains to each system has been installed to manufacturer's instructions.
4. Carry out tests in presence of Consultant.
5. Provide instruments, meters, equipment and personnel required to conduct tests during and at conclusion of project.
6. Submit test results for Consultant's review.

1.18. DEMOLITION

1. Disconnect and make safe electrical equipment and services as required on site.
2. Be responsible for demolition and removal of electrical equipment and services designated on drawings for removal and as required by work unless specified otherwise under other divisions.
3. Electrical work being removed by other division shall be carried out under direction of this division. Do all disconnecting prior to authorizing removal.

1.19. FIREPROOFING

1. Where cables or conduits pass through floors and fire rated walls, pack space between wiring and sleeve full with firestopping system to CAN 4-S115.

1.20. EXISTING SYSTEMS

1. Before submitting tender price verify on job site location of all accessible existing electrical systems affecting execution of this contract. Difficulties arising during construction will not be considered as grounds for additional payment.
2. Where work involves breaking into or connecting to existing systems, carry out work at times directed by governing authorities, with minimum of disturbance to pedestrian traffic.
3. Submit schedule to and obtain approval from Consultant for any shut down or closure of active service or facility. Adhere to approved schedule and provide notice to affected parties.
4. Where unknown services are encountered, immediately advise Consultant and confirm findings in writing.

1.21. OWNER OCCUPANCY SCHEDULE

1. The existing building will remain occupied during normal occupancy hours.
2. Provide temporary protection for all finishes, appliances or equipment in the existing building.

END OF SECTION 16010

PART 1- GENERAL

1.1. GENERAL

1. Division 1, General Requirements is part of this Section and shall apply as if repeated here.

1.2. REFERENCES

1. Canadian Standards Association (CSA)
 1. CSA C22.2 No. 18-98 (R2003), Outlet Boxes, Conduit Boxes, and Fittings and Associated Hardware.
 2. CSA C22.2 No. 56-04 (R2009), Flexible Metal Conduit and Liquid-Tight Flexible Metal Conduit.
 3. CSA C22.2 No. 83-M1985(R2013), Electrical Metallic Tubing.

1.3. WASTE MANAGEMENT AND DISPOSAL

1. Separate and recycle waste materials in accordance with Division 1.
2. Place materials defined as hazardous or toxic waste in designated containers.
3. Ensure emptied containers are sealed and stored safely for disposal away from children.
4. Collect and separate plastic, paper packaging and corrugated cardboard in accordance with Division 1.

PART 2- PRODUCTS

2.1. CONDUITS

1. Electrical metallic tubing (EMT): with steel couplings, sized as indicated.
2. Flexible metal conduit and liquid-tight flexible metal conduit, sized as indicated.

2.2. CONDUIT FASTENINGS

1. One hole steel straps to secure surface conduits 50 mm (2") and smaller. Two hole steel straps for conduits larger than 50 mm (2").
2. Beam clamps to secure conduits to exposed steel work.

3. Channel type supports for two or more conduits at 3 m (9') o/c.
4. 6 mm dia threaded rods to support suspended channels.

2.3. CONDUIT FITTINGS

1. Fittings: manufactured for use with conduit specified. Coating: same as conduit.
2. Fittings to be suitable sized for conduit used.
3. Fittings used for EMT to be steel, not cast.
4. Factory "ells" where 90° bends are required for 25 mm (1") and larger conduits.

2.4. EXPANSION FITTINGS FOR RIGID CONDUIT

1. Weatherproof expansion fittings with internal bonding assembly suitable for 100 or 200 mm linear expansion.
2. Watertight expansion fittings with integral bonding jumper suitable for linear expansion and 19 mm deflection in all directions.
3. Weatherproof expansion fittings for linear expansion at entry to panel.

2.5. FISH CORD

1. Polypropylene.

PART 3- EXECUTION

3.1. INSTALLATION

1. Install conduits to conserve headroom in exposed locations and cause minimum interference in spaces through which they pass.
2. Conceal conduits except in mechanical and electrical service rooms and in unfinished areas.
3. Use electrical metallic tubing (EMT) above 2.4 m not subject to mechanical injury.
4. Use flexible metal conduit for final connection to devices in ceiling space max. length 3 m.
5. Use liquid tight flexible metal conduit for final connection to a vibrating piece of equipment.
6. Bend conduit cold. Replace conduit if kinked or flattened more than 1/10th of its original diameter.
7. Mechanically bend steel conduit over 21 mm diameter.

Project Number: 6637

8. All unterminated conduit ends to be reamed and protected by insulating bushings.
9. Install fish cord in empty conduits and all conduits 53 mm and greater.
10. Where conduits become blocked, remove and replace blocked section. Do not use liquids to clean out conduits.
11. Dry conduits out before installing wire.
12. Use water tight fittings at connections to taps or sides of sprinkler proof equipment or seal with approved sealant.

3.2. SURFACE CONDUITS

1. Run parallel or perpendicular to building lines.
2. Locate conduits behind infrared or gas fired heaters with 1500 mm clearance.
3. Run conduits in flanged portion of structural steel.
4. Group conduits wherever possible on suspended channels.
5. Do not pass conduits through structural members except as indicated.
6. Do not locate conduits less than 75 mm (3") parallel to steam or hot water lines with minimum of 25 mm (1") at crossovers.
7. All exposed conduits in areas other than service spaces are to be painted to match existing finishes.

END OF SECTION 16111

PART 1- GENERAL

1.1. RELATED SECTIONS

1. Division 1, General Requirements is part of this Section and shall apply as if repeated here.
2. Section 16151 – Wire and Box Connections – 0 – 1000V.

1.2. REFERENCES

1. CSA C22.2 No. 0.3-09, Test Methods for Electrical Wires and Cables.

1.3. PRODUCT DATA

1. Submit product data in accordance with Division 1.

1.4. WASTE MANAGEMENT AND DISPOSAL

1. Separate and recycle waste materials in accordance with Division 1.
2. Collect and separate plastic, paper packaging and corrugated cardboard in accordance with Division 1.
3. Fold up metal banding, flatten and place in designated area for recycling.

PART 2- PRODUCTS

2.1. GENERAL

1. All conductors to be copper, unless otherwise noted.

2.2. BUILDING WIRES

1. All conductors to be copper, unless otherwise noted.
2. Conductors: stranded for 10 AWG and larger. Minimum size: 12 AWG for power and # 16 AWG for controls and fire alarm.
3. Copper conductors: size as indicated, with insulation of chemically cross-linked thermosetting polyethylene material type RW90, or with thermoplastic insulation and nylon jacket, type T-90 nylon.
4. 600V rating for nominal 208V system voltage; 1000V rating for nominal 600V system

voltage.

5. All outdoor circuit conductors, including service entrance conductors to be type RWU90 or USEI-90, unless otherwise noted.
6. Wire and conduit sizes shown are based on RW75 XLPE and are minimum sizes. Contractor is responsible for wire and conduit sized for other approved wires.
7. Conductors shall be colour coded. Conductors size 10 AWG and smaller shall have colour impregnated into insulation at time of manufacture.
 1. Colour code wiring for 120 / 208 Volt equipment as follows
 1. Phase conductors: Red, Black, Blue
 2. Neutral conductors: White
 3. Bonding to ground: Green

2.3. ARMoured CABLES

1. Conductors insulated copper sizes as indicated, minimum wire size #12 AWG.
2. Type: AC90.
3. Armour: interlocking type fabricated from aluminum strip.
4. Connectors: to suit.
5. Fastenings:
 1. One hole steel straps to secure surface cables 25 mm and smaller. Two hole steel straps for cables larger than 25 mm.
 2. Channel type supports for two or more cables at 1500 mm centres.
 3. Threaded rods: 6 mm dia. To support suspended channels.
6. Approved compression type lugs accurately sized to allow bolted connections at each cable end.
7. All wiring shall be concealed in floor slabs, walls, ceiling and furred spaces. AC90 armoured cable may be used only for drops to fixtures, maximum length 3 m in concealed ceiling spaces, or drops to receptacles in GWB partitions, maximum length 4.5 m. Otherwise cables shall be in EMT conduit.

2.4. CONTROL CABLES

1. Type LVT: 2 soft annealed copper conductors sized as indicated with thermoplastic insulation and outer covering thermoplastic jacket.

2. Plenum rated cable (FT-6) required in ceiling space where not in conduit.

PART 3- EXECUTION

3.1. INSTALLATION OF BUILDING WIRES

1. Install wiring in conduit in accordance with Section 16111, unless otherwise noted.
2. Use type RW90 where required by Ontario Electrical Safety Code, for all panelboard feeders and for all conductors sized 250 MCM and larger.
3. Use type RW90 or T-90 for branch circuit wiring unless otherwise indicated.
4. Minimum wire size shall be No. 12 AWG. For 15A, 120V branch circuit home runs which exceed 23 m length shall be minimum No. 10 AWG, and minimum No. 8 AWG for runs which exceed 36 m. For 20A, 120V branch circuit home runs which exceed 17 m in length shall be minimum No. 10 AWG, and minimum No. 8 AWG for runs which exceed 27 m. Where existing wiring is re-used, minimum wire sizes shall apply and wiring shall be replaced when it does not meet the minimum size.
5. Existing wiring may only be re-used if permitted by Engineer.

3.2. INSTALLATION OF ARMOURED CABLES

1. Use only for drops to fixtures maximum length 3 m in concealed ceiling spaces, or drops to receptacles in GWB partitions maximum length 4.5 m.
2. Terminate cables in accordance with Section 16151.
3. Installation of all single conductor armoured cable shall be in such a way as to prevent the flow of sheath currents (current flow in the sheath caused by induced voltage on the sheath), as per Ontario Electrical Safety Code Rule 4-008. To prevent the flow of sheath currents, it is necessary to make sure that all paths (at terminations and supports) in which they may circulate are eliminated. Cable sheaths shall be grounded at the supply end termination only and isolated from ground and each other at the load end termination by a minimum of a 6 mm thick insulated material plate. Provide a lamacoid at the supply end of the conductors indicating "ENSURE CABLES ARE INSTALLED TO PREVENT SHEATH CURRENTS".

3.3. INSTALLATION OF CONTROL CABLES

1. Install control cables in conduit in accordance with Section 16111.
2. Ground control cable shield.

END OF SECTION 16122

PART 1- GENERAL

1.1. GENERAL

1. Division 1, General Requirements is part of this Section and shall apply as if repeated here.

1.2. REFERENCES

1. CSA C22.1-12 Canadian Electrical Code, Part 1.

1.3. WASTE MANAGEMENT AND DISPOSAL

1. Separate and recycle waste materials in accordance with Division 1, and with the Waste Reduction Workplan.
2. Collect and separate plastic, paper packaging and corrugated cardboard in accordance with Division 1.

PART 2- PRODUCTS

2.1. OUTLET AND CONDUIT BOXES - GENERAL

1. Size boxes in accordance with CSA C22.1.
2. 102 mm (4") square or larger outlet boxes as required for special devices.
3. Gang boxes where wiring devices are grouped.
4. Blank cover plates for boxes without wiring devices.
5. Combination boxes with barriers where outlets for more than one system are grouped.

2.2. SHEET STEEL OUTLET BOXES

1. Electro-galvanized steel single and multi gang flush device boxes for flush installation, minimum size 76 x 50 x 38 mm or as indicated. 102 mm (4") square outlet boxes when more than one conduit enters one side with extension and plaster rings as required.
2. Electro-galvanized steel utility boxes for outlets connected to surface-mounted EMT conduit, minimum size 102 x 54 x 48 mm
3. 102 mm (4") square or octagonal outlet boxes for lighting fixture outlets.
4. 102 mm (4") square outlet boxes with extension and plaster rings for flush mounting devices in finished tile walls.

2.3. CONDUIT BOXES

1. Cast FS or FD ferrous boxes with factory-threaded hubs and mounting feet for surface wiring of switches and receptacle.
2. Electro-galvanized utility tape for indoor surface wiring.

2.4. FITTINGS - GENERAL

1. Bushing and connectors with nylon insulated throats.
2. Knock-out fillers to prevent entry of debris.
3. Conduit outlet bodies for conduit up to 35 mm and pull boxes for larger conduits.
4. Double locknuts and insulated bushings on sheet metal boxes.

PART 3- EXECUTION

3.1. INSTALLATION

1. Support boxes independently of connecting conduits.
2. Fill boxes with paper, sponges or foam or similar approved material to prevent entry of debris during construction. Remove upon completion of work.
3. For flush installations mount outlets flush with finished wall using plaster rings to permit wall finish to come within 6 mm of opening.
4. Provide correct size of openings in boxes for conduit, mineral insulated and armoured cable connections. Reducing washers are not allowed.

END OF SECTION 16132

PART 1 - GENERAL

1.1. GENERAL

1. Division 1, General Requirements is part of this Section and shall apply as if repeated here.

1.2. REFERENCES

1. CSA C22.2 No. 65-13 Wire Connectors.
2. EEMAC 1Y-2, 1961 Bushing Stud Connectors and Aluminum Adapters (1200 Ampere Maximum Rating).

PART 2 - PRODUCTS

2.1. MATERIALS

1. Pressure type wire connectors: with current carrying parts of copper sized to fit copper conductors as required.
2. Fixture type splicing connectors: with current carrying parts of copper sized to fit copper conductors 10 AWG or less.
3. Bushing stud connectors: to EEMAC 1Y-2 to consist of:
 1. Connector body and stud clamp for stranded copper conductors.
 2. Clamp for stranded copper conductors
 3. Stud clamp bolts.
 4. Bolts for copper conductors
 5. Sized for conductors as indicated.
4. Clamps or connectors for armoured cable, flexible conduit, as required.

PART 3 - EXECUTION

3.1. INSTALLATION

1. Remove insulation carefully from ends of conductors and:
 1. Apply coat of zinc joint compound on aluminum conductors prior to installation of connectors.

2. Install mechanical pressure type connectors and tighten screws with appropriate compression tool recommended by manufacturer. Installation shall meet secureness tests in accordance with CSA C22.2 No.65.
3. Install fixture type connectors and tighten. Replace insulating cap.
4. Install bushing stud connectors in accordance with EEMAC 1Y-2.

END OF SECTION 16151

PART 1 - GENERAL

1.1. RELATED WORK

1. Division 1, General Requirements is part of this Section and shall apply as if repeated here.
2. Fastenings and supports: Section 01600 Material and Equipment.

PART 2 - PRODUCTS

2.1. SUPPORT CHANNELS

1. U shape, size 41 x 41 x 2.5 mm thick, surface mounted or suspended.
2. Smaller sections subject to Consultant's approval.

PART 3 - EXECUTION

3.1. INSTALLATION

1. Secure equipment to tile and plaster surfaces with nylon anchors, with independent grip protrusions.
2. Secure equipment to poured concrete with expandable inserts.
3. Secure equipment to hollow masonry walls or suspended ceilings with toggle bolts.
4. Secure equipment to Siporex ceiling with Aircrete anchors equal to Fischer p/n:GB14.
5. Support equipment, conduit or cables using clips, spring loaded bolts, cable clamps designed as accessories to basic channel members.
6. Fasten exposed conduit or cables to building construction or support system using straps.
 1. One-hole steel straps to secure surface conduits and cables 50 mm and smaller.
 2. Two-hole steel straps for conduits and cables larger than 50 mm.
 3. Beam clamps to secure conduit to exposed steel work.
7. Suspended support systems.
 1. Support individual cable or conduit runs with 6 mm dia threaded rods and spring clips.

2. Support 2 or more cables or conduits on channels supported by 6 mm dia threaded rod hangers where direct fastening to building construction is impractical.
8. For surface mounting of two or more conduits use channels at 3 m oc spacing.
9. Provide metal brackets, frames, hangers, clamps and related types of support structures where indicated or as required to support conduit and cable runs.
10. Ensure adequate support for raceways and cables dropped vertically to equipment where there is no wall support.
11. Do not use wire lashing or perforated strap to support or secure raceways or cables.
12. Do not use supports or equipment installed for other trades for conduit or cable support except with permission of other trade and approval of Consultant.
13. Install fastenings and supports as required for each type of equipment cables and conduits, and in accordance with manufacturer's installation recommendations.
14. All fastenings and supports to be hot dipped galvanized. All cut ends exposing base material to be completely sealed with field applied coating to give equivalent protection prior to installation. Following complete installation, all damage to protective layer to be carefully and completely touched up with same field applied coating.

END OF SECTION 16191

PART 1- GENERAL

1.1. GENERAL

1. Division 1, General Requirements is part of this Section and shall apply as if repeated here.

1.2. PRODUCT DATA

1. Submit product data in accordance with Division 1.

PART 2- PRODUCTS

2.1. DISCONNECT SWITCHES

1. Enclosed manual air break switches in non-hazardous locations to CSA C22.2 No. 4-04 (2009).
2. Fuse holder assemblies to CSA C22.2 No. 39-13.
3. Fusible and non-fusible disconnect switch in CSA Enclosure size as indicated.
4. Provision for padlocking in on-off switch position by three locks.
5. Mechanically interlocked door to prevent opening when handle in ON position.
6. Fuses: size as indicated, to Section 16478 - Fuses - Low Voltage.
7. Fuse holders: suitable without adaptors, for type and size of fuse indicated.
8. Quick-make, quick-break action.
9. ON-OFF switch position indication on switch enclosure cover.

2.2. EQUIPMENT IDENTIFICATION

1. Provide equipment identification in accordance with Section 16010 - Electrical General Requirements.
2. Indicate name of load controlled on size 4 nameplate.

2.3. ACCEPTABLE MATERIALS

1. Square D
2. Cutler-Hammer

PART 3- EXECUTION

3.1. INSTALLATION

1. Install disconnect switches complete with fuses, if applicable.
2. For all disconnects where fuse and wire sizes have a lower rating than the disconnect, a lamacoid label is to be applied indicating "MAX FUSE SIZE TO BE ____ AMPS". To be filled in with the value of the specific fuse size.

END OF SECTION 16440

PART 1- GENERAL

1.1. GENERAL

1. Division 1, General Requirements is part of this Section and shall apply as if repeated here.

1.2. REFERENCES

1. OESC Section 10, Bonding and Grounding.

PART 2 - PRODUCTS

2.1. EQUIPMENT

1. Insulated grounding conductors: green, type TWH.
2. Non-corroding accessories necessary for grounding system, type, size, material as indicated, including but not necessarily limited to:
 1. Grounding and bonding bushings.
 2. Protective type clamps.
 3. Bolted type conductor connectors.
 4. Thermit welded type conductor connectors.
 5. Bonding jumpers, straps.
 6. Pressure wire connectors.

PART 3- EXECUTION

3.1. EQUIPMENT GROUNDING

1. Install grounding connections to typical equipment included in, but not necessarily limited to following list. Service equipment, transformers, switchgear, duct systems, frames of motors, motor control centres, starters, control panels, building steel work, generators, elevators and escalators, distribution panels and outdoor lighting.

3.2. FIELD QUALITY CONTROL

1. Perform tests in accordance with Section 16010 - Electrical General Requirements.

2. Perform ground continuity tests using method appropriate to site conditions and to approval of Consultant and Inspection Authority.
 1. Ground continuity: Ensure, through ground loop resistance measurement, that the grounding for the new equipment is tied in satisfactorily to the existing ground grid. Continuity measurements should be made between new equipment and system grounds of existing 600V services.
 2. Perform tests before energizing electrical system.
3. Coordinate scheduling of tests with testing agency. Provide all test results to consultant.

END OF SECTION 16450

PART 1- GENERAL

1.1. GENERAL

1. Division 1, General Requirements is part of this Section and shall apply as if repeated here.

1.2. PRODUCT DATA

1. Submit product data in accordance with Division 1.
2. Include time-current characteristic curves for breakers with ampacity of 400A and over or with interrupting capacity of 22,000A symmetrical (rms) and over at system voltage.

PART 2- PRODUCTS

2.1. BREAKERS - GENERAL

1. Bolt-on moulded case circuit breaker: quick-make, quick-break type, for manual and automatic operation with temperature compensation for 40°C ambient.
2. Common-trip breakers: with single handle for multi-pole applications.
3. Magnetic instantaneous trip elements in circuit breakers to operate only when value of current reaches setting. Trip settings on breakers with adjustable trips to range from 3-10 times current rating.

2.2. THERMAL MAGNETIC BREAKERS

1. Moulded case circuit breaker to operate automatically by means of thermal and magnetic tripping devices to provide inverse time current tripping and instantaneous tripping for short circuit protection.

PART 3- EXECUTION

3.1. INSTALLATION

1. Install circuit breakers as indicated.

END OF SECTION 16477

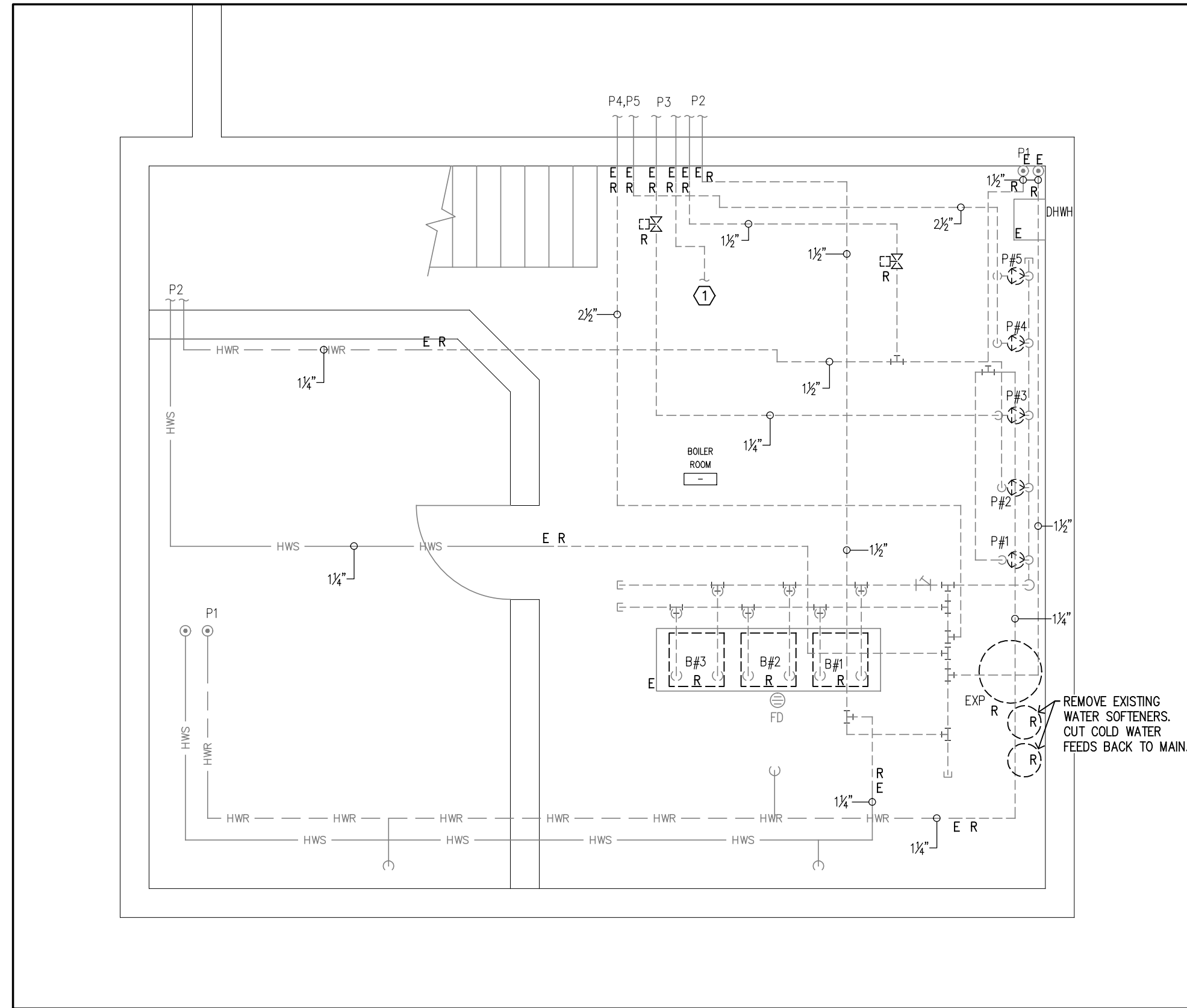

1 Boiler Room Floor Plan - Piping and Valves - Demolition
M101 1/4" = 1'-0"

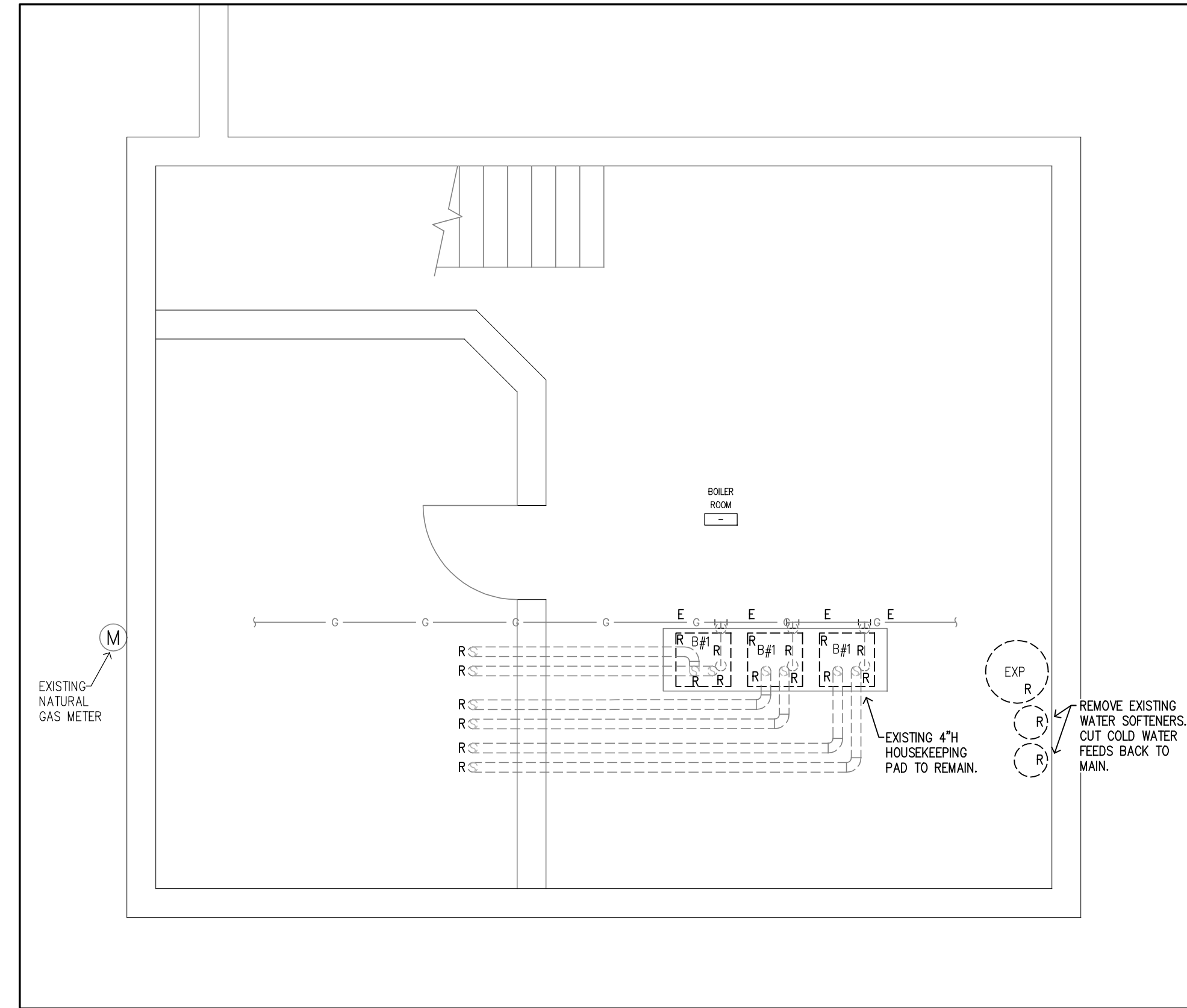

2 Boiler Room Floor Plan - Venting and Gas - Demolition
M101 1/4" = 1'-0"

PLUMBING LEGEND

—HWS—	HOT WATER SUPPLY
—HWR—	HOT WATER RETURN
—CWP—	COLD WATER PIPING
—SSB—	SANITARY SEWER BELOW
—C/P—	CAPPED PIPING
○	PIPE RISER
○	PIPE DROP
○	COMBINATION PIPE RISE AND DROP
⊙	FLOOR DRAIN
⊙	FUNNEL FLOOR DRAIN
⊙	HOSE BIB
⊙	GAS METER
⊙	CHECK VALVE
⊙	STRAINER
⊙	BALANCING VALVE
⊙	THERMOMETER
⊙	RELIEF VALVE - EXTEND TO DRAIN
⊙	PRESSURE GAUGE
⊙	GLOBE VALVE
⊙	BALL VALVE
⊙	BUTTERFLY VALVE
⊙	UNION
⊙	AUTOMATIC AIR VENT
⊙	BACK FLOW PREVENTER
⊙	FLOW SWITCH
⊙	PRESSURE REDUCING ASSEMBLY
4"	DUCT WITH DIMENSIONS
⊙	FIRE EXTINGUISHER
R	EXISTING DEVICE TO BE REMOVED
RL	EXISTING DEVICE TO BE RELOCATED
E	EXISTING DEVICE TO REMAIN
ER	EXISTING DEVICE TO BE REPLACED

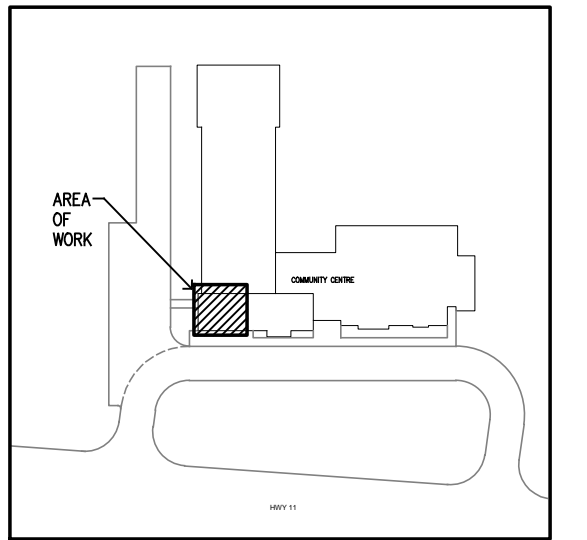

Key Plan
N.T.S.

BOILER UPGRADE GENERAL NOTES:

- ALL CONTROL WIRING BETWEEN BOILER, BOILER CIRCULATORS, AND TEMPERATURE SENSORS BY MECHANICAL CONTRACTOR.
- BOILER CONTROLLER SHALL CONTROL EACH BOILER, SUPPLY AND RETURN WATER TEMPERATURE. INTERFACE BOILER CONTROLLER WITH P#1 TO P#5.
- INSULATE AND CANVAS ALL OLD AND NEW PIPING UNDER THIS CONTRACT. (BOILER ROOM ONLY)
- RESTORE HEATING SYSTEM TO PREVIOUS CONDITION DURING BOILER START-UP, BLEED ALL LINES.
- PERFORM FINAL BOILER START-UP DURING BUILDING HEATING LOAD. (OCTOBER/NOVEMBER)
- PATCH ALL OPENINGS AFTER MECHANICAL ELECTRICAL REMOVALS.
- BALANCE FLOWS TO VOLUMES SHOWN. SUBMIT DETAILED REPORT.
- PVC TO BE USED FOR CONDENSATE PIPING.
- REINSTATE AND PVC WRAP EXISTING PIPING IN BOILER ROOM (HOT WATER HEATING AND DOMESTIC HOT & COLD WATER).

MECHANICAL GENERAL NOTES:

- FIRE STOP ALL PENETRATIONS THROUGH FIRE RATED ASSEMBLIES.
- REMOVE ALL UNUSED EQUIPMENT, PIPING, DUCTWORK, ETC. CUT CAP AND MAKE SAFE.
- VERIFY ALL POINTS OF CONNECTION TO EXISTING SERVICES PRIOR TO ROUGH-IN.
- PROVIDE CLEARANCE TO EQUIPMENT AS PER MANUFACTURERS RECOMMENDATIONS.
- DOUBLE CHECK VALVE ASSEMBLY SERVING BOILER MAKE UP WATER TO BE MOUNTED 750mm TO 1500mm ABOVE FINISHED FLOOR. A CLEAR SPACE OF 750mm IN FRONT OF THE DOUBLE CHECK VALVE ASSEMBLY IS REQUIRED. PROVIDE 1/2" FUNNEL TYPE RELIEF DRAIN C/W 1" AIR GAP BELOW CHECK VALVE - EXTEND TO NEAREST DRAIN.

ZONE VALVE NOTES:

- ZV#2 1/2" STAINLESS STEEL BALL AND STEM, ON/OFF, NORMALLY OPEN, UNIVERSAL VOLTAGE, BELIMO B231, AFRBUP. (TIE INTO EXISTING STAT).
- ZV#3 1/2" STAINLESS STEEL BALL AND STEM, ON/OFF, NORMALLY OPEN, UNIVERSAL VOLTAGE, BELIMO B239, AFRBUP. (TIE INTO EXISTING STAT).

DRAWING NOTES NOTES:

- ① REMOVE PIPING UP TO SUPPLY HEADER.

1. ISSUED FOR TENDER	23.12.07
----------------------	----------

revision	date
----------	------

the Contractor shall check and verify all dimensions before proceeding with the work

ⓐ detail no.
ⓑ sheet no. where detailed

Drawings are a property of Piotrowski Consultants Ltd. and are protected by copyright. Reproduction of any kind is strictly prohibited.



PIOTROWSKI
Consultants Limited
1820 Bond St. North Bay, Ontario, P1B 4V6
Ph. 705-472-2536 Fx. 705-476-5105
Email - pci@piotrowskiconsultants.ca

project
MUNICIPALITY OF VAL RITA-HARTY
COMMUNITY CENTRE
BOILER SYSTEM UPGRADES

VAL RITA-HARTY ONTARIO

title
MECHANICAL AND ELECTRICAL
PARTIAL FLOOR PLANS,
LEGEND & NOTES

drawn by: AL	date: DECEMBER 2023
-----------------	------------------------

checked by: TK	project no: 6637
-------------------	---------------------

scale: AS NOTED	dwg no: M101
--------------------	-----------------

plotted: December 6, 2023	
------------------------------	--

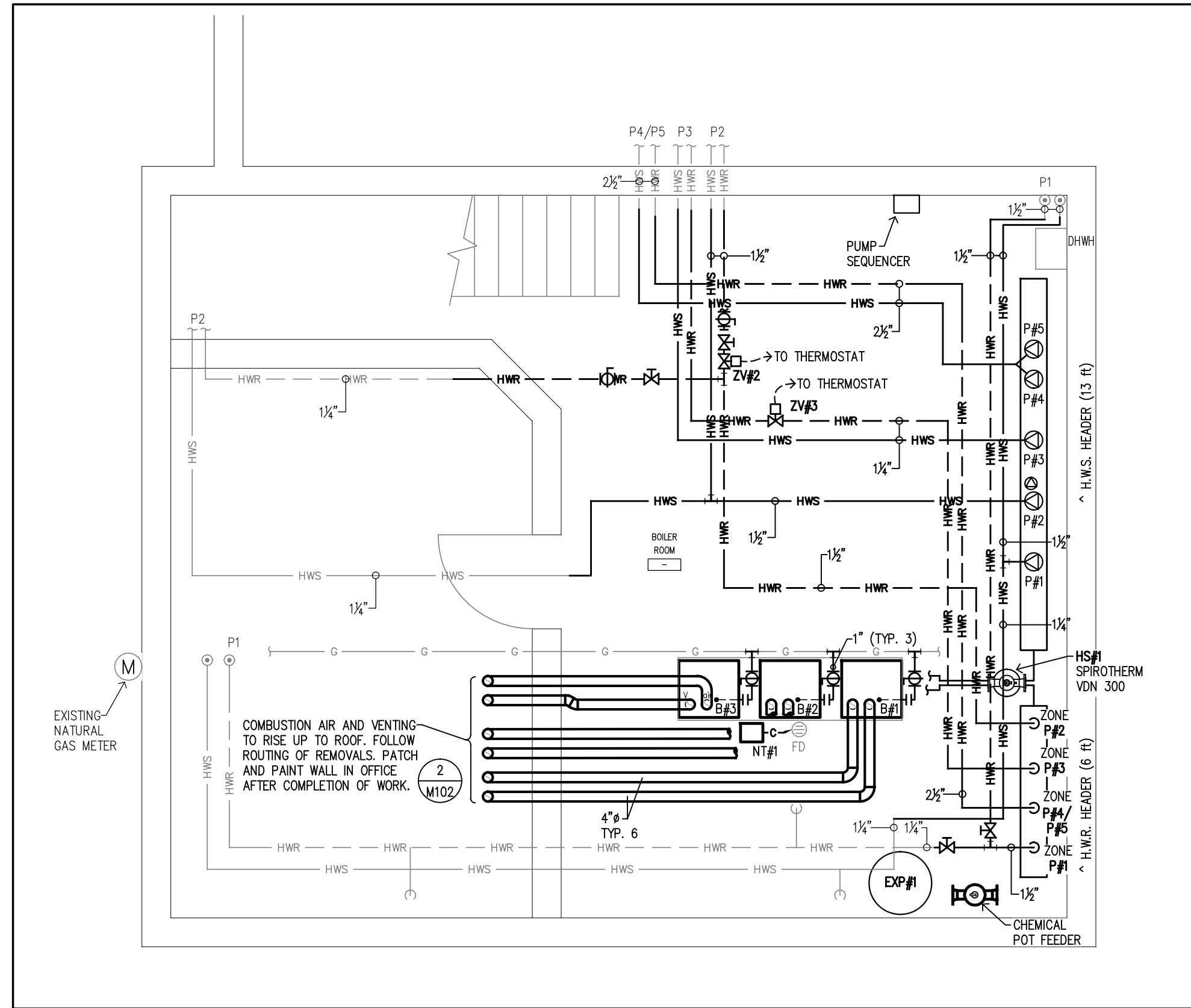

1 Boiler Room Floor Plan - New
M102 1/4" = 1'-0"

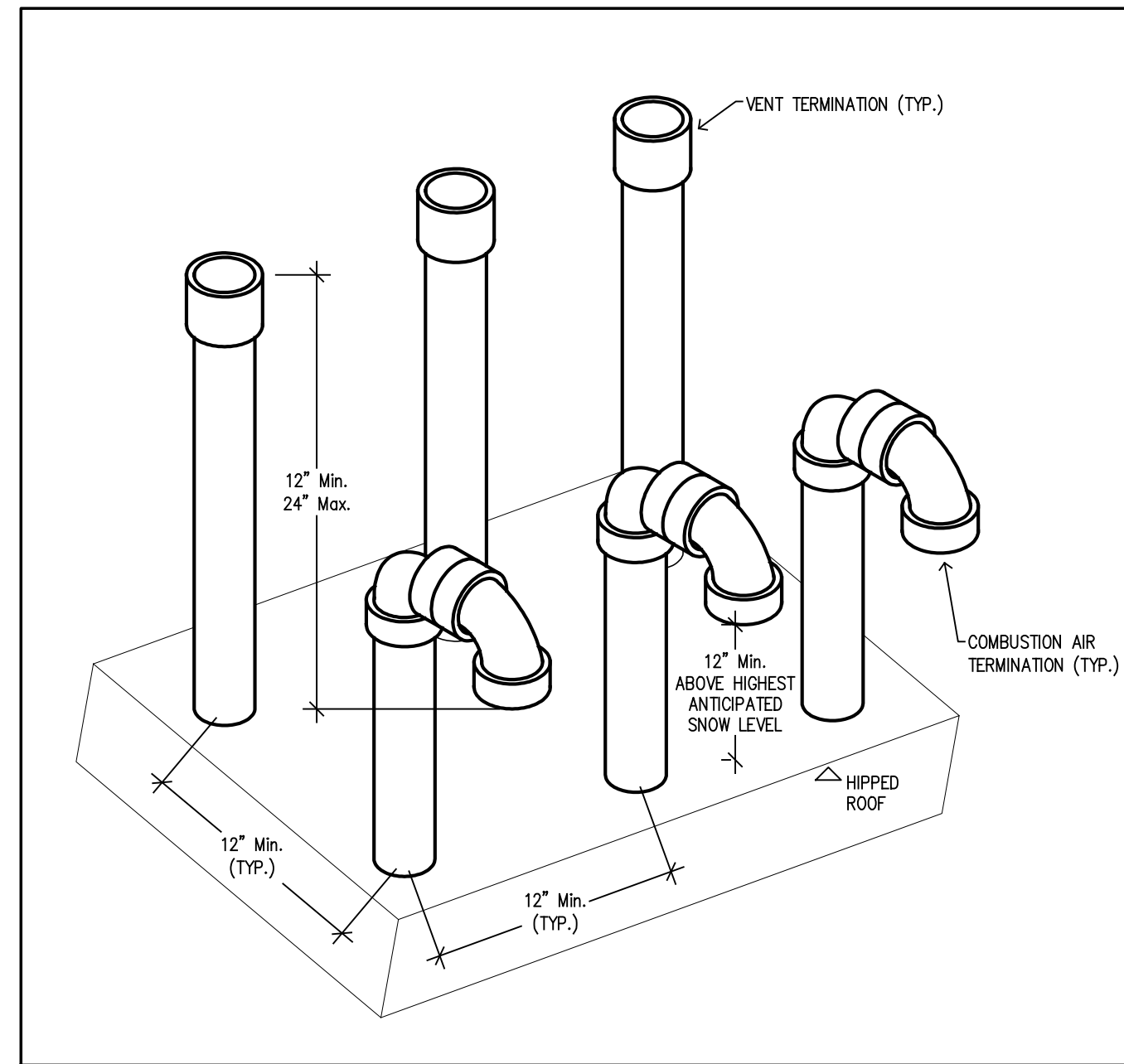

2 Direct Vent - Vertical Termination of Vent and Combustion Air Piping
M102 NTS

Pump Schedule						
No.	MODEL BY WLO	FLOW (GPM)	HEAD (FT H ₂ O)	MOTOR AND POWER	MEDIA & TEMPERATURE	NOTES
BP#1	TOP S 1.25x35-1	38	13.35'	120V / SP 0.41 HP	WATER 71°C (160°F)	
BP#2	TOP S 1.25x35-1	38	13.35'	120V / SP 0.41 HP	WATER 71°C (160°F)	
BP#3	TOP S 1.25x35-1	38	13.35'	120V / SP 0.41 HP	WATER 71°C (160°F)	
P#1	STRATOS-MAXO 1.25x3-35	20	30'	120V / SP 0.35	WATER 20°C (68°F)	C/W BUILT-IN VFD.
P#2	STRATOS-MAXO 1.25x3-35	20	30'	120V / SP 0.35	WATER 71°C (160°F)	C/W BUILT-IN VFD.
P#3	STRATOS-MAXO 1.25x3-35	13	30'	120V / SP 0.35	WATER 20°C (68°F)	C/W BUILT-IN VFD.
P#4	STRATOS-MAXO 2x3-50	60	35'	120V / SP 0.93	WATER 71°C (160°F)	C/W BUILT-IN VFD.
P#5	STRATOS-MAXO 2x3-50	60	35'	120V / SP 0.93	WATER 71°C (160°F)	C/W BUILT-IN VFD.

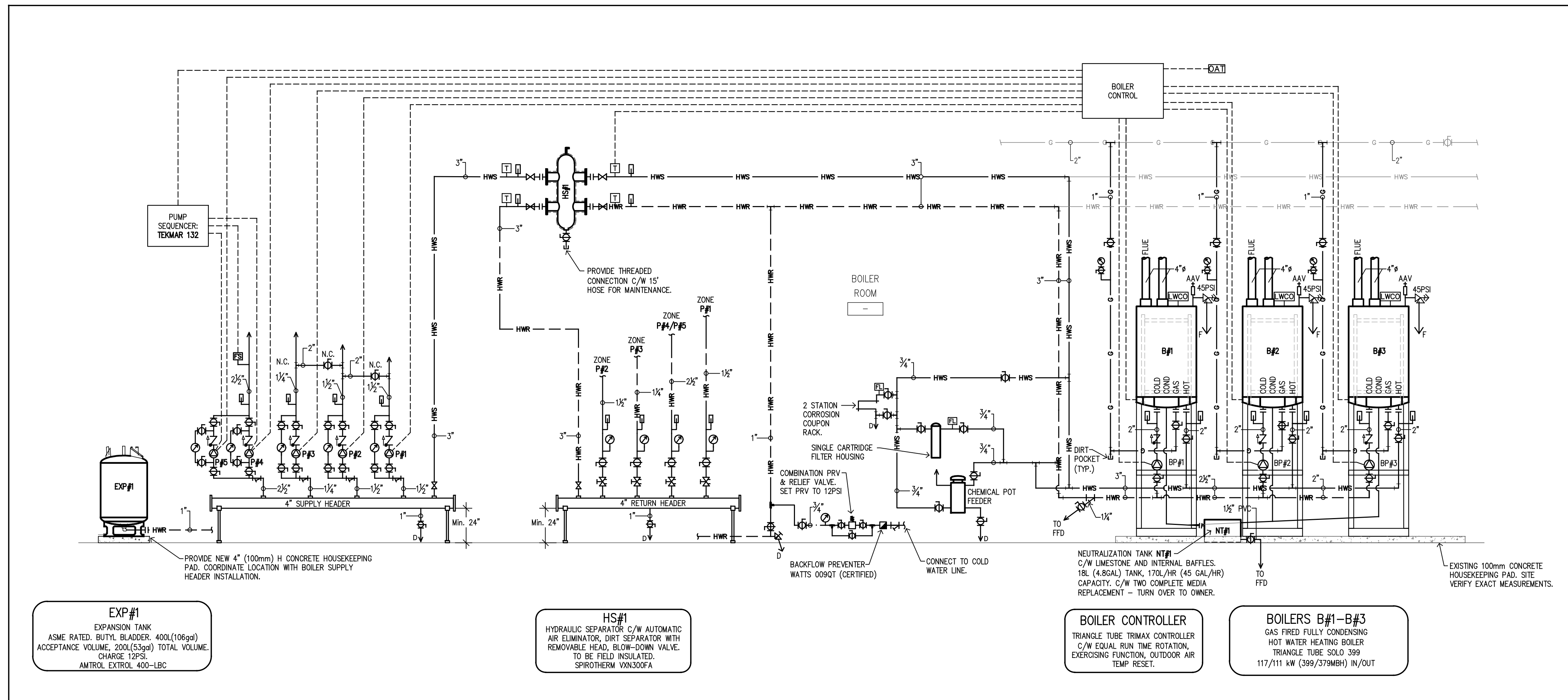

3 Boiler Riser Diagram
M102 NTS

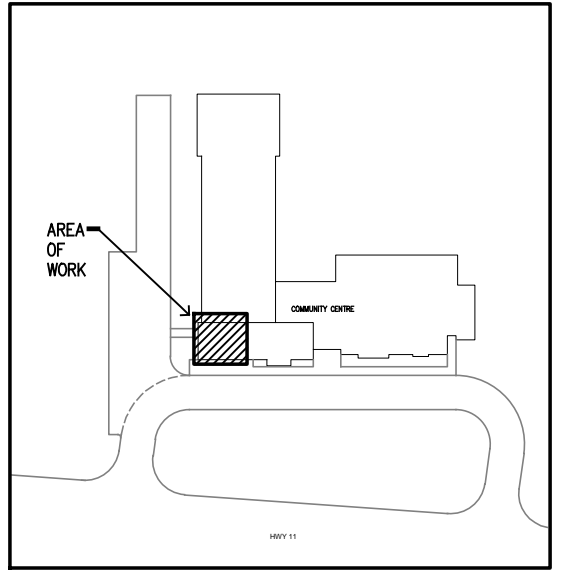

Key Plan
N.T.S.

1. ISSUED FOR TENDER 23.12.07

revision date

the Contractor shall check and verify all dimensions before proceeding with the work

A detail no.
B sheet no. where detailed

Drawings are a property of Piotrowski Consultants Ltd. and are protected by copyright. Reproduction of any kind is strictly prohibited.

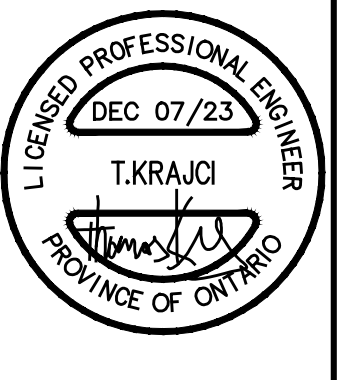

PIOTROWSKI
Consultants Limited
1820 Bond St. North Bay, Ontario, P1B 4V6
Ph. 705-472-2536 Fx. 705-476-5105
Email - pci@piotrowskiconsultants.ca

project
MUNICIPALITY OF VAL RITA-HARTY
COMMUNITY CENTRE
BOILER SYSTEM UPGRADES

VAL RITA-HARTY ONTARIO

title
MECHANICAL AND ELECTRICAL
PARTIAL FLOOR PLAN,
SCHEDULE, DETAIL
& BOILER RISER DIAGRAM

drawn by: AL date: DECEMBER 2023

checked by: TK project no: 6637

scale: AS NOTED dwg no: M102

plotted: December 6, 2023

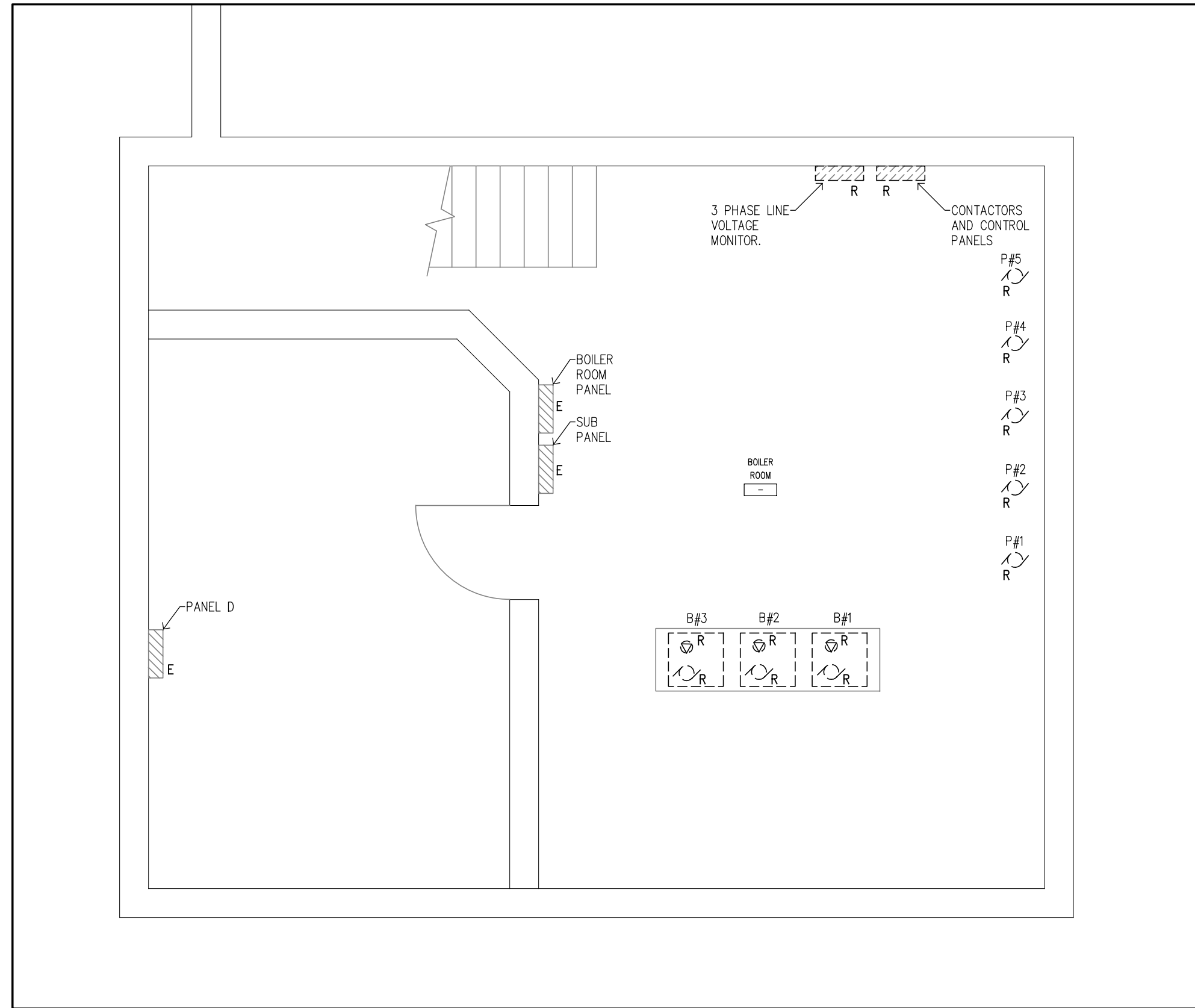

1 Boiler Room Floor Plan - Power - Demolition
E101 1/4" = 1'-0"

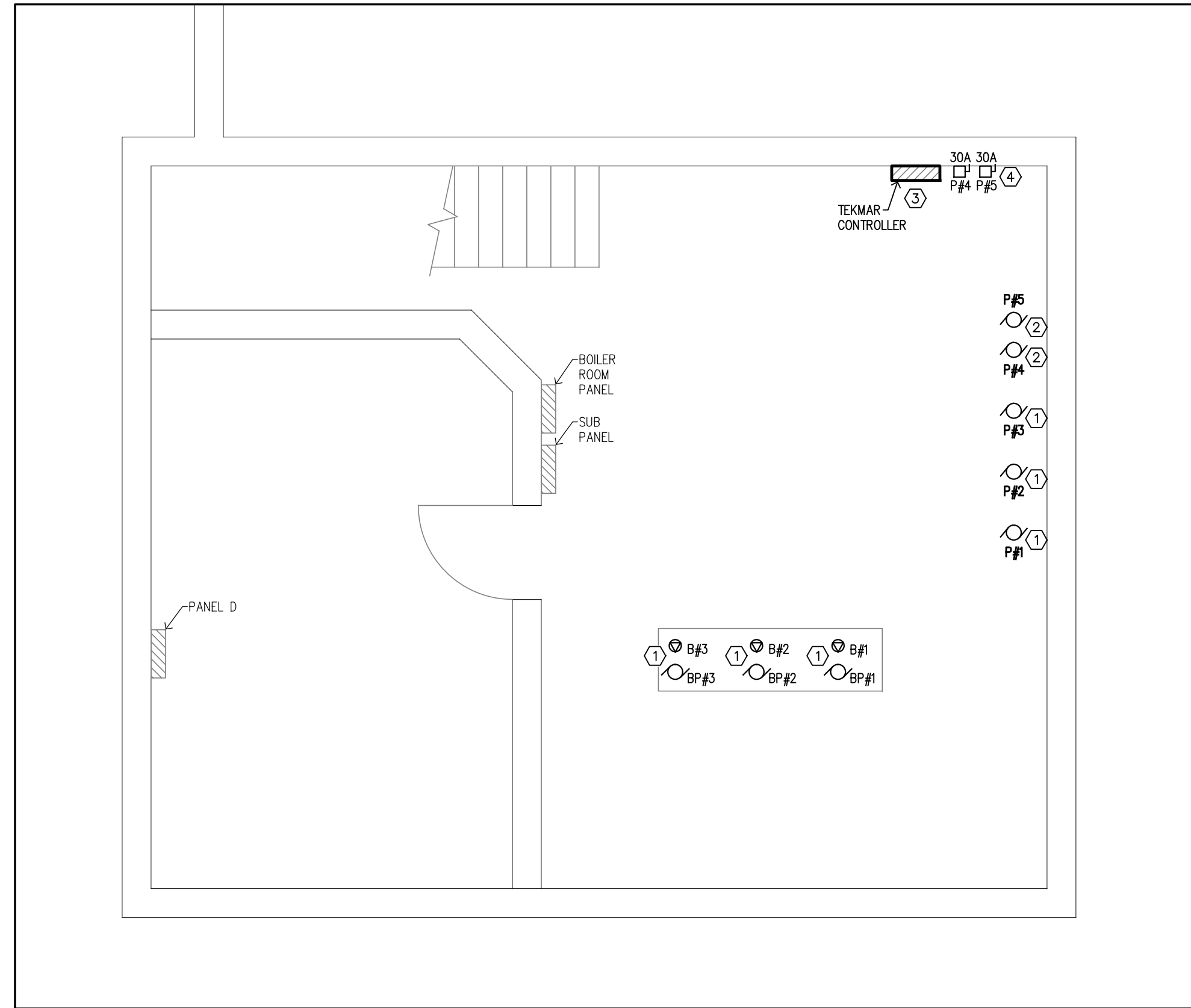

2 Boiler Room Floor Plan - Power - New
E101 1/4" = 1'-0"

ELECTRICAL LEGEND

- EPX ELECTRICAL PANEL, SURFACE MOUNTED (DESIGNATION AS SHOWN)
- SAFETY DISCONNECT SWITCH - UNFUSED
- DIRECT CONNECTION FOR EQUIPMENT
- MOTOR CONNECTION
- R EXISTING DEVICE TO BE REMOVED
- RL EXISTING DEVICE TO BE RELOCATED
- E EXISTING DEVICE TO REMAIN
- ER EXISTING DEVICE TO BE REPLACED WITH NEW

ELECTRICAL GENERAL NOTES:

1. ENTIRE INSTALLATION SHALL BE IN ACCORDANCE WITH THE ONTARIO ELECTRICAL SAFETY CODE.
2. ELECTRICAL CONTRACTOR IS TO OBTAIN ALL APPROVALS FROM LOCAL ELECTRICAL SAFETY AUTHORITY PRIOR TO COMMENCING WORK.
3. ALL DEVICES SHOWN ARE NEW, UNLESS OTHERWISE NOTED.
4. FIRE STOP ALL PENETRATIONS THRU FIRE RATED ASSEMBLIES.
5. ALL UNUSED WIRING SHALL BE PROPERLY TERMINATED, OR REMOVED. WIRING THAT CANNOT BE REMOVED AND IS CONCEALED AND UNACCESSIBLE MUST BE CUT OFF WHERE EXPOSED (SO AS TO BE TOO SHORT TO BE REUSED) AND BE MADE SAFE.

POWER GENERAL NOTES:

1. PROVIDE BONDING CONDUCTOR AND CONNECTION (AS PER OESC) FOR ALL PERMANENTLY CONNECTED EQUIPMENT. COORDINATE EXACT REQUIREMENTS ON SITE.
2. ELECTRICAL CONTRACTOR TO PROVIDE THE DEVICE AND ROOM LOCATION INFORMATION ON ALL CIRCUITS IN THE PANEL SCHEDULE. (FOR EXAMPLE, RECEIPT - RM 100)
3. PROVIDE CLEAR LABELS ON ALL EQUIPMENT INDICATING PANEL AND CIRCUIT NUMBERING. (FOR EXAMPLE PNL#A CCT 11.)

DRAWING NOTES:

- ① EXISTING EQUIPMENT IS FED FROM BOILER ROOM SUB PANEL. RE-USE EXISTING WIRING AND EXTEND FROM NEAREST JUNCTION BOX TO NEW EQUIPMENT AS REQUIRED.
- ② EXISTING PUMP IS FED FROM A 3-POLE BREAKER IN PANEL D. PROVIDE NEW 20A, 2-POLE BREAKER FOR NEW PUMP. NEW BREAKER TO BE OF SAME MANUFACTURER AND HAVE SAME KVAIC RATING AS EXISTING BREAKERS. EXISTING WIRING MAY BE RE-USED. MAKE UNUSED CONDUCTOR SAFE.
- ③ POWER WIRING FOR PUMP #4 & #5 SHALL RUN THROUGH THE TEKMAR CONTROLLER. CONSULT MANUFACTURER'S INSTALLATION INSTRUCTIONS.
- ④ MOTOR DISCONNECTING MEANS TO BE LOCATED ON LOAD SIDE OF TEKMAR CONTROLLER.

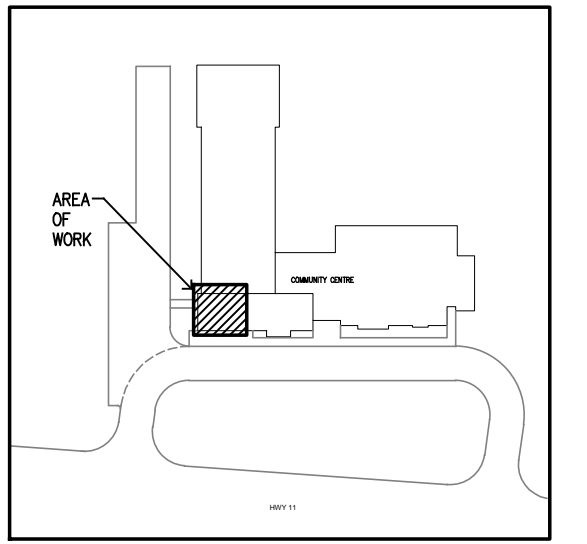

Key Plan

N.T.S.

1. ISSUED FOR TENDER	23.12.07
----------------------	----------

revision	date
----------	------

the Contractor shall check and verify all dimensions before proceeding with the work

A detail no.
B sheet no. where detailed

Drawings are a property of Piotrowski Consultants Ltd. and are protected by copyright. Reproduction of any kind is strictly prohibited.

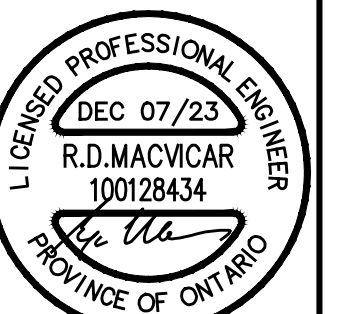

PIOTROWSKI
Consultants Limited
1820 Bond St. North Bay, Ontario, P1B 4V6
Ph. 705-472-2536 Fx. 705-476-5105
Email - pci@piotrowskiconsultants.ca

project
MUNICIPALITY OF VAL RITA-HARTY
COMMUNITY CENTRE
BOILER SYSTEM UPGRADES

VAL RITA-HARTY ONTARIO

title
ELECTRICAL
POWER
PARTIAL FLOOR PLANS,
LEGEND & NOTES

drawn by: AL	date: DECEMBER 2023
-----------------	------------------------

checked by: RM	project no: 6637
-------------------	---------------------

scale: AS NOTED	dwg no: E101
--------------------	------------------------

plotted: December 7, 2023
